

# STAR WARS

# RETURN OF THE

# JEDI

## BATTLE AT SARLACC'S PIT™

### RULES AND ASSEMBLY INSTRUCTIONS

*For 2 to 4 players*  
*Ages 7 to 12*

Rules © 1983 Parker Brothers, Beverly, MA 01915. Printed in U.S.A. TM: © 1983 Lucasfilm Ltd. (LFL)  
Characters and Designs © 1983 Lucasfilm Ltd. (LFL)



LUKE  
SKYWALKER



HAN  
SOLO



PRINCESS  
LEIA ORGANA



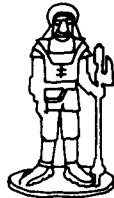
CHEWBACCA



GAMORREAN  
GUARD



BOBA  
FETT



NIKTO



JABBA  
THE HUTT

## OBJECT

JABBA THE HUTT has captured our favorite heroes—LUKE SKYWALKER, PRINCESS LEIA ORGANA, HAN SOLO, and CHEWBACCA. They're being held on a Sail Barge over the sandpit where the monster SARLACC lives. Help the heroes escape! Collect JEDI points as you defeat each guard on the Sail Barge. Then overpower JABBA THE HUTT. The one with the most JEDI points at the end of the game is the winner.

## EQUIPMENT

Special three-dimensional game board (see "Game Assembly Instructions") • 17 plastic playing pieces: 4 heroes (LUKE SKYWALKER, PRINCESS LEIA ORGANA, HAN SOLO, and CHEWBACCA), 10 GAMORREAN GUARDS, 1 SKIFF GUARD (NIKTO), 1 BOUNTY HUNTER (BOBA FETT) • 48 cards: 13 white JEDI point cards and 35 black playing cards (19 Number cards, 6 "THE FORCE™" cards, 6 Direction cards, 4 JABBA THE HUTT cards) • a card holder

**NOTE:** Detach the figures from the runners by using a twisting motion. Then carefully trim any remains of the runner from the figures. After all the figures have been removed, dispose of the runner.

## SET UP

1. Assemble the three-dimensional game board (see "Game Assembly Instructions," page 3).
2. Place JABBA THE HUTT onto the black hexagon (●) in the center of the Top Deck on the Sail Barge.
3. Place NIKTO and BOBA FETT onto each of the tan, red-lined pentagons with the circle in the middle (⊙), located directly below the Top Deck.
4. Place the 10 GAMORREAN GUARDS onto each of the tan, red-lined pentagons with the square in the middle (⊠), located on either side of the Main Deck of the Sail Barge.
5. Each player chooses a hero and places it onto the Detention Area of the Sail Barge.
6. Arrange the white JEDI point cards **face up** in a pile so the 1-point cards are on top, followed by the 2-point cards and then the 4-point card. Place the card pile next to the game board.
7. Separate the JABBA THE HUTT cards from the black playing deck and put them aside.
8. Shuffle the rest of the black playing deck, then deal four cards **face down** to each player.
9. Mix the JABBA THE HUTT cards with the remaining black playing deck, then place them **face down** in a pile on one side

of the card holder. This is the **draw pile**.

10. The player to the left of the dealer goes first. Play then proceeds, in turn, to the first player's left.

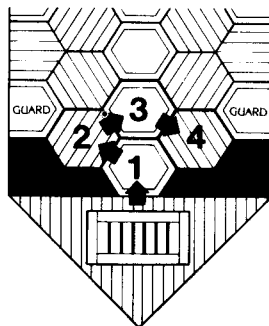
## PLAYING

On your turn, you'll do these things, in the following order:

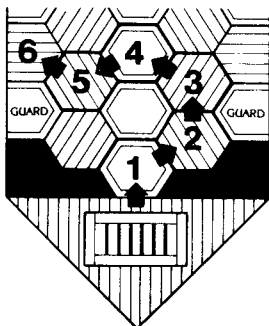
1. Play **ONE** of your cards by placing it **face up** in the card holder, next to the draw pile. This is the **discard pile**.
2. Follow the directions for the card you play:
  - If you play a *Number card*, move your hero the number of spaces indicated.
  - If you play a "*THE FORCE™*" card, move your hero any number of spaces from 1 to 6.
  - If you play a *Direction card*, follow the directions given on that card.
3. If you challenge a guard, follow the directions for challenging that guard (see "Challenging a Guard").
4. Always **end** your turn with 4 cards in your hand.

### I. PLAYING A NUMBER CARD

Place a Number card **face up** onto the discard pile. When you play this card, move your hero the number of spaces indicated on the card. You can move in **any direction or combination of directions**, as shown in Figures 1 and 2.



**Figure 1.** Movement of hero, if you've played a "4" card.



**Figure 2.** Movement of hero, if you've played a "6" card or "THE FORCE™" card.

Try to move to a space **next to** one occupied by a guard. This means you're challenging that guard. Refer to the section, "Challenging a Guard."

When you move your hero, you can count a space that's occupied by another hero as part of the number you move. However, you can't end your turn on a space occupied by another hero.

If you're in the Detention Area at the start of your turn, you must begin your move on the tan hexagon with the arrow on it.

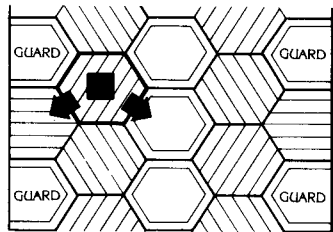
NOTE: If you don't move to a space next to one occupied by a guard, pick the top card from the draw pile. If it's not a JABBA THE HUTT card, keep the card and end your turn. But if it is, refer to "IV. DRAWING A JABBA THE HUTT CARD."

### CHALLENGING A GUARD

All the GAMORREAN GUARDS must be defeated before you challenge NIKTO and BOBA FETT. To challenge a guard:

1. Move onto a space next to a guard by playing a number card, "THE FORCE™" card, or "Move To Any Empty Space."
2. Draw the top card from the draw pile.
  - If you draw a **Number** or "THE FORCE™" card, you've defeated the guard! Push the guard off the Sail Barge and into SARLACC'S PIT. Then move your hero to the space the guard occupied. Collect a JEDI point card equal to the value of the guard: GAMORREAN GUARD = 1 point, NIKTO = 2 points, BOBA FETT = 2 points.
  - If you draw a **Direction card** or a **JABBA THE HUTT** card, the guard has defeated your hero. Move your hero back to the Detention Area.
3. Keep the card you drew, unless it was a JABBA THE HUTT card. Place the JABBA THE HUTT card **face up** onto the discard pile, and refer to "IV. DRAWING A JABBA THE HUTT CARD."

At the start of your turn, if JABBA THE HUTT is on one of the grey spaces on the Top Deck that's at the end of the line of spaces you're on, you can't play a Number card. To move, you must play "THE FORCE™" card. If you don't have one to play or don't wish to use "THE FORCE™" card, you may move only ONE space to the side and behind the space you occupy. (See Figure 3.)



**Figure 3.** Movement of hero, if JABBA THE HUTT is occupying a space at the end of the line of spaces you're on at the start of your turn.

## II. PLAYING "THE FORCE™" CARD

Play "THE FORCE™" card **face up** onto the discard pile. When you play this card, move your hero **any number of spaces from 1 to 6**. You can move in **any direction or combination of directions**, as shown in Figures 1 and 2.

Try to move to a space **next** to one occupied by a guard. This means you're challenging that guard. Refer to the section, "Challenging a Guard."

With "THE FORCE™" card, you can move even if JABBA THE HUTT is occupying one of the grey spaces at the end of the line of spaces you're on.

If you're in the Detention Area at the start of your turn, you must begin your move on the tan hexagon with the arrow on it.

If you don't move to a space next to one occupied by a guard, pick the top card from the draw pile. If it's not a JABBA THE HUTT card, keep the card and end your turn. But if it is, refer to "IV. DRAWING A JABBA THE HUTT CARD."

## III. PLAYING A DIRECTION CARD

There are three types of Direction cards. They may be used only on your turn, never when they're first drawn.

1. *Move To Any Empty Space:* Place the card **face up** onto the discard pile. Then move your hero to any empty space. However, don't move to a space on the Top Deck unless all the guards have been defeated and you're prepared to challenge JABBA THE HUTT.
  - If you move to a space next to one occupied by a guard, challenge that guard.
  - If you don't move next to a guard, take the top card from the draw pile. If it's not a JABBA THE HUTT card, keep the card and end your turn. But if it is, refer to "IV. DRAWING A JABBA THE HUTT CARD."
2. *Change Places With Any Player:* Place the card **face up** onto the discard pile. Move your hero to a space occupied by the hero of any player. Then move that player's hero to the space you occupied—even if you were in the Detention Area! After you move, take the top card from the draw pile. If it's not a JABBA THE HUTT card, keep the card and end your turn. But if it is, refer to "IV. DRAWING A JABBA THE HUTT CARD."
3. *Take "THE FORCE™" Card From Any Player:* Place the card **face up** onto the discard pile. Then ask ONE player to give you one of his or her "THE FORCE™" cards.
  - If that player has one, he or she must give it to you. Then end your turn. (NOTE: If a player takes "THE FORCE™" card from you, **don't** take a card from the draw pile. Begin your next turn with 3 cards in your hand. At the end of your turn, take the top two cards from the draw pile to have 4

cards in your hand. If you challenge a guard on your turn, use the **first card** you draw to determine whether or not you've defeated the guard.

- If that player doesn't have "THE FORCE™" card, end your turn. Don't draw a card from the draw pile. (Refer to the previous NOTE.)

#### IV. DRAWING A JABBA THE HUTT CARD

Every time you draw this card:

1. Immediately place it **face up** onto the discard pile.
2. Move JABBA THE HUTT onto any one of the five grey spaces on the Top Deck.
3. Take the top card from the draw pile. If it's not a JABBA THE HUTT card, end your turn.

**NOTE:** When there are no more cards in the draw pile, shuffle the cards in the discard pile. Then place them **face down** in a pile on one side of the card holder to make a new draw pile.

#### DEFEATING JABBA THE HUTT

Once all the GAMORREAN GUARDS, NIKTO, and BOBA FETT have been defeated, players try to defeat JABBA THE HUTT in one of two ways:

1. Move onto a space **next to** the one occupied by JABBA THE HUTT by playing a Number card, "THE FORCE™" card, or "Move To Any Empty Space." Defeat JABBA THE HUTT by playing "THE FORCE™" card from your hand. (This means you must play two cards on this turn—one card to move, and "THE FORCE™" card to defeat JABBA THE HUTT.)

OR

2. Move onto a space **next to** the one occupied by JABBA THE HUTT by playing a Number card, "THE FORCE™" card, or "Move To Any Empty Space." Then defeat JABBA THE HUTT by drawing "THE FORCE™" card from the top of the draw pile.

If you defeat JABBA THE HUTT by either way, collect the 4-point JEDI card. The game then ends.

If you don't defeat JABBA THE HUTT, move your hero back to the Detention Area. Play continues until someone defeats JABBA THE HUTT.

#### WINNING

Count your JEDI points at the end of the game. The one who has the most JEDI points is the winner. If there's a tie for the most points, you're both winners!

We will be happy to answer your questions or comments about STAR WARS: RETURN OF THE JEDI Battle At Sarlacc's Pit. Contact the Consumer Response Department in the location nearest you:

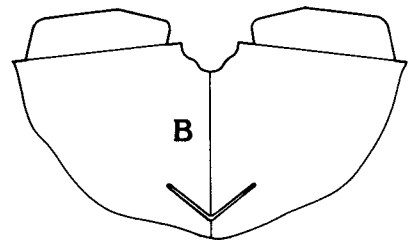
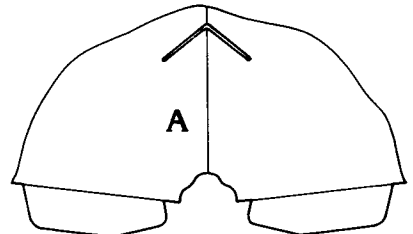
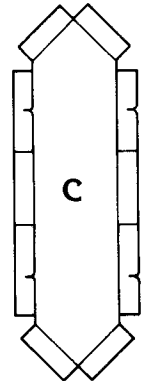
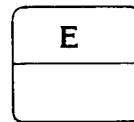
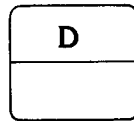
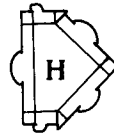
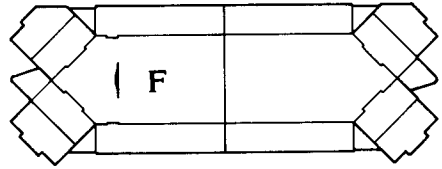
In the U.S.A.: Parker Brothers, P.O. Box 1012, Beverly, MA 01915.

In Australia and New Zealand: Parker Games, 104 Bourke Road, Alexandria, N.S.W. 2015.

In the United Kingdom: Parker Games, Owen Street, Coalville, Leicester LE6 2DE England.

#### GAME ASSEMBLY INSTRUCTIONS

The game will be played on the Main Deck of the Sail Barge over the sandpit where the monster SARLACC lives. To build the scene for the game's action, first carefully remove all 8 pieces from the perforated sheet. Then spread the pieces out on a flat surface to match the diagram below. Be sure you place each piece so its identifying name and letter shows.



You're now ready to begin a step-by-step assembly of the Sail Barge, which consists of the following pieces:

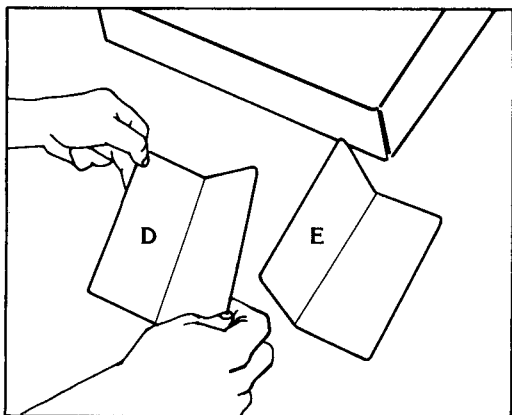
- 2 Sail Barge supports (**D and E**)
- a stabilizer (**C**)
- 2 SARLACC'S PIT walls (**A and B**)
- a Sail Barge (**F**)
- a Top Deck (**H**)
- a railing (**G**)

Place the bottom of the box the game package came in next to your assembly area. You'll use this half of the box in which to build your Sail Barge.

## I. THE SAIL BARGE SUPPORTS (D and E)

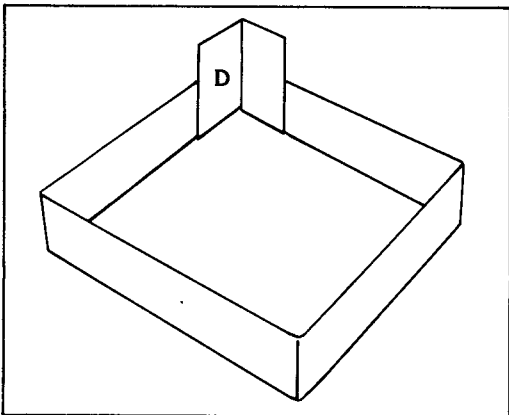
a. Fold each Sail Barge support along the scored line. (See Figure 1.)

Figure 1.



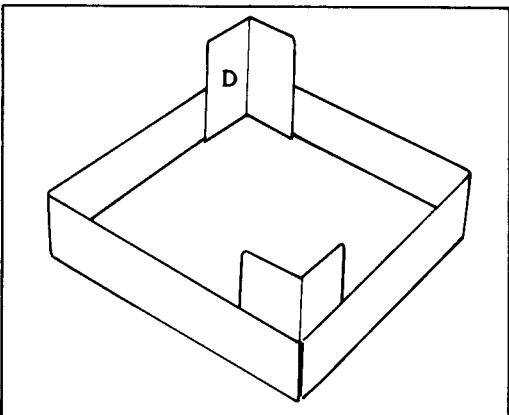
b. Place one of the supports so the fold fits easily into one corner of the box, as shown in Figure 2.

Figure 2.



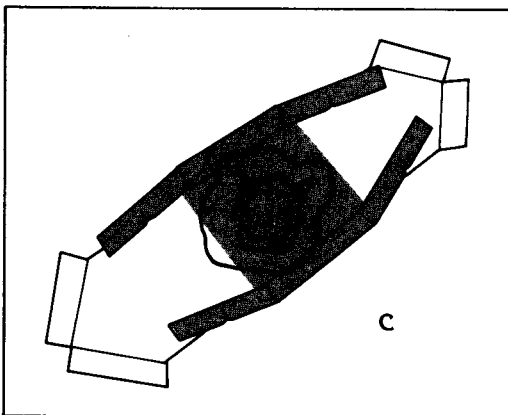
c. Place the other Sail Barge support into the corner diagonally across from the first support you placed. (See Figure 3.)

Figure 3.



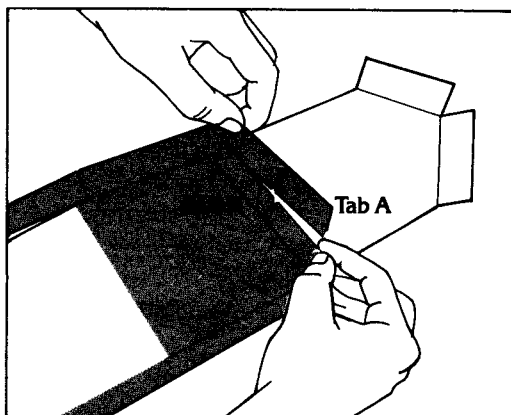
## II. THE STABILIZER (C)

a. Tear gently at the perforations on the right and left sides to make four flaps. Then fold along each of the scored lines. After you've done so, it should look like Figure 4.



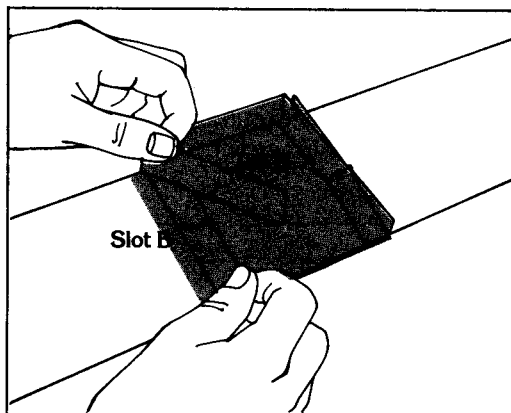
b. Hold Slot A firmly in place as shown in Figure 5, and insert Tab A into it.

Figure 5.



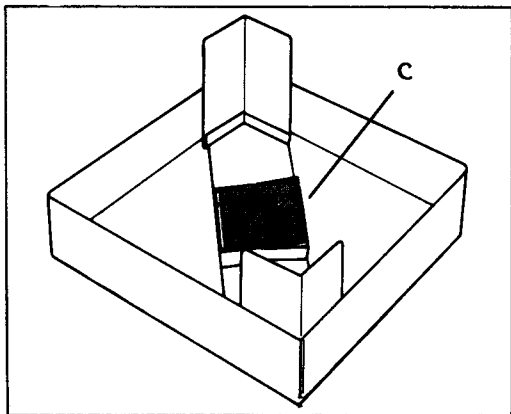
Then hold Slot B in place as shown in Figure 6, and insert Tab B into it.

Figure 6.



c. Now place the stabilizer piece diagonally across the inside of the box so it fits between the Sail Barge supports. (See Figure 7.)

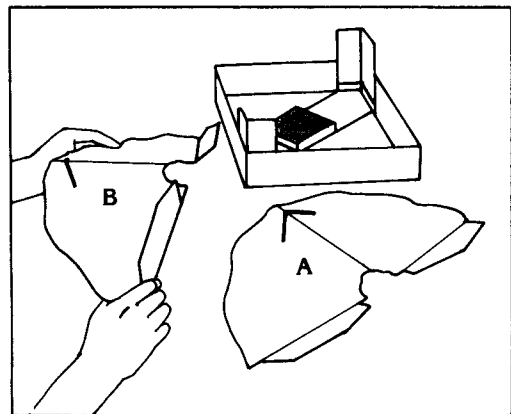
Figure 7.



### III. SARLACC'S PIT WALLS (A and B)

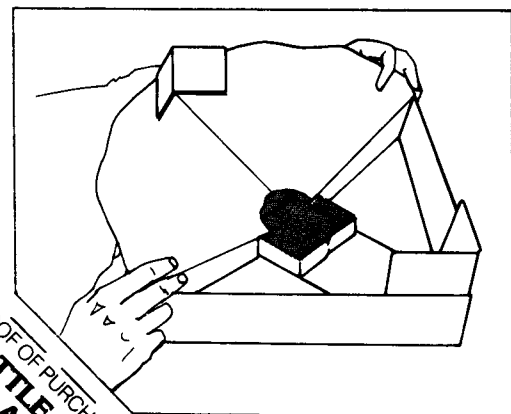
a. Carefully punch out the perforated "V"-shaped areas on each wall. Then fold along each of the scored lines. After you've done so, the walls should look like Figure 8.

Figure 8.



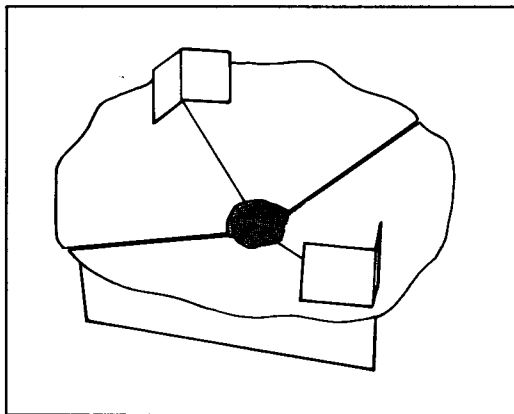
b. Now turn one wall piece over. Place the "V" over one of the Sail Barge supports so the support pokes through the "V." Slide the pit wall down, then tuck the folded flaps in to meet the corners of the box. Slide the wall down until the notched area meets the stabilizer. (See Figure 9.)

Figure 9.



c. Now turn the other wall piece over and place it into position as you did in Step b. You've made SARLACC'S PIT! (See Figure 10.)

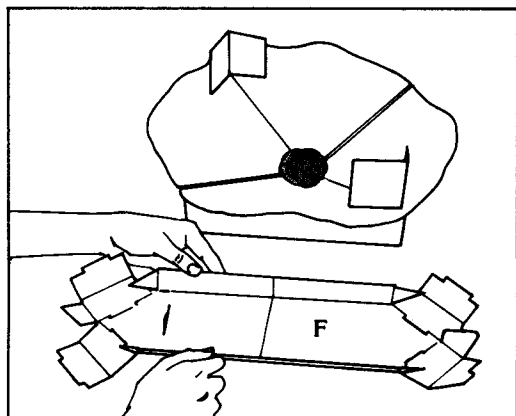
Figure 10.



### IV. THE SAIL BARGE (F)

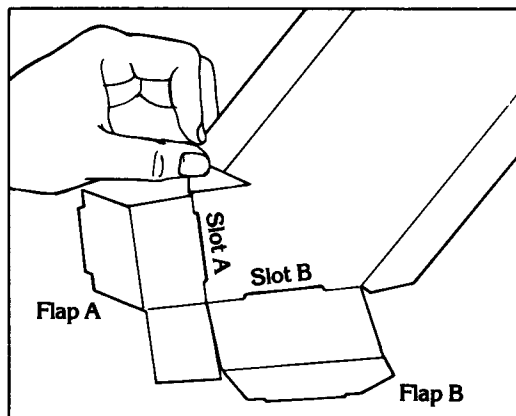
a. Carefully punch out the perforated line at one end of the Sail Barge. Then tear gently at the perforated areas and fold along each of the scored lines. After you do so, the Sail Barge should look like Figure 11.

Figure 11.



b. Place the end with Flap A/Slot A and Flap B/Slot B in front of you. Hold the left side (Flap A side) of the Sail Barge up as shown, with the triangular piece folded in at a right angle to the side. (See Figure 12.)

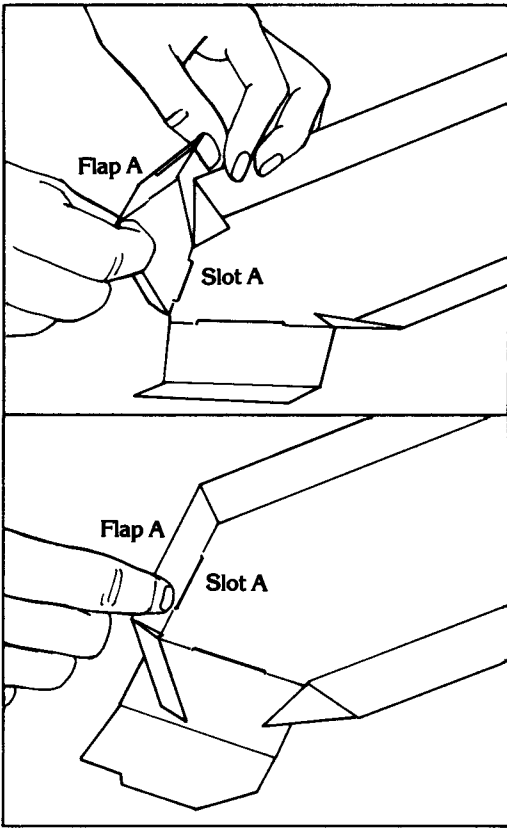
Figure 12.



PROOF OF PURCHASE  
BATTLE AT  
SARLACC'S  
PIT™

c. Then take Flap A and bend it over the triangular piece, as shown in Figure 13. Then insert Flap A into Slot A, as shown in Figure 14.

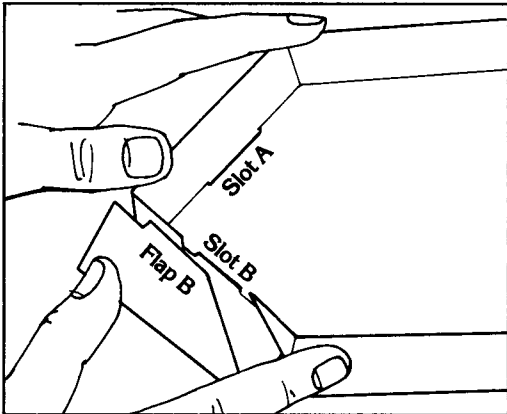
**Figure 13.**



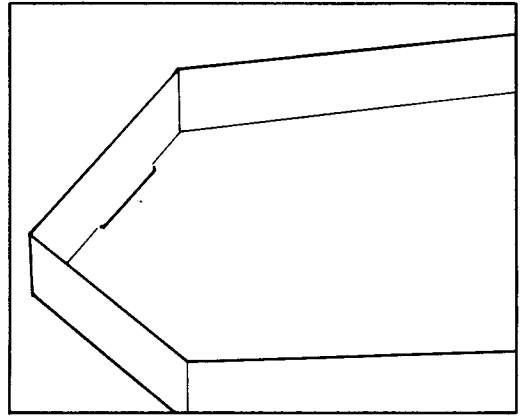
**Figure 14.**

d. Then take Flap B and bend it as before over the other triangular piece and the rectangular piece, as shown in Figure 15. Then insert Flap B into Slot B. (See Figure 16.)

**Figure 15.**

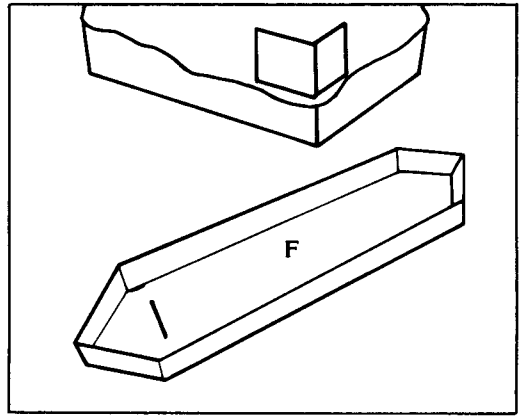


**Figure 16.**



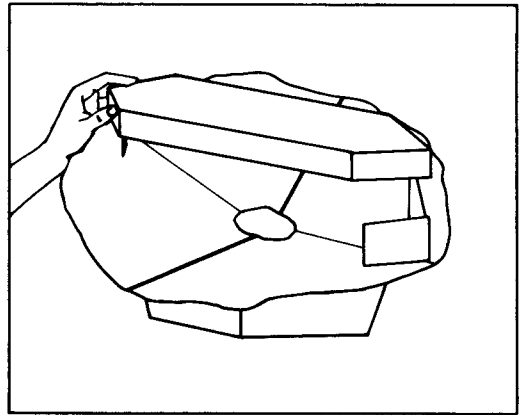
e. Now do the same to the opposite end of the Sail Barge. Insert Flap C into Slot C and Flap D into Slot D. The Sail Barge now looks like Figure 17.

**Figure 17.**



f. Turn the Sail Barge over, then place it on top of the Sail Barge supports so the supports slip inside of the "V"-shaped ends of the Sail Barge. (See Figure 18.)

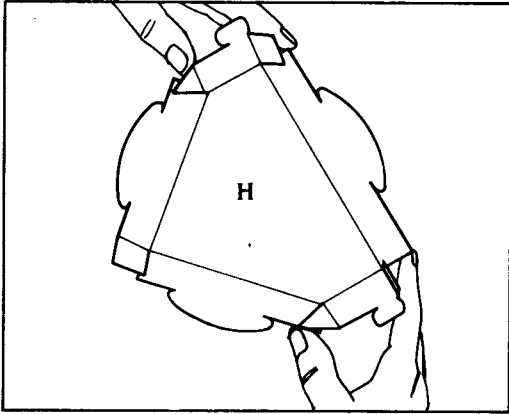
**Figure 18.**



## V. THE TOP DECK (H)

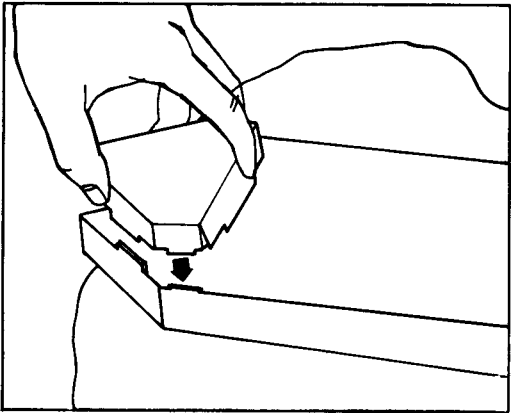
a. Fold along each of the scored lines, as shown in Figure 19.

Figure 19.



b. Match the tabs on the deck piece to the three slots on the end of the Sail Barge. Then gently push the deck tabs into the slots, as shown in Figure 20.

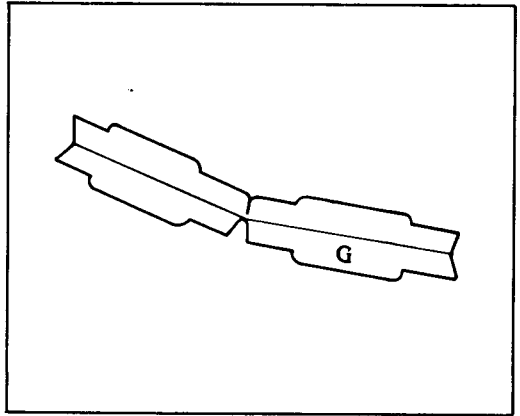
Figure 20.



## VI. THE RAILING (G)

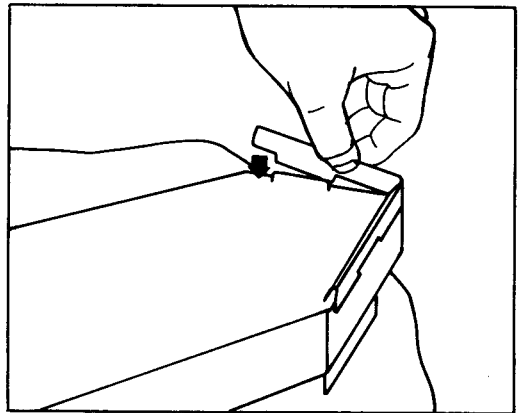
a. Fold along each of the scored lines, as shown in Figure 21.

Figure 21.



b. Match the tabs on this piece to the slots on the other end of the Sail Barge. Then gently push the railing tabs into the slots, as shown in Figure 22.

Figure 22.



Now you've assembled the game, and you're ready to begin the BATTLE AT SARLACC'S PIT! (See Figure 23.)

Figure 23.

