

Contains: Body, 2 scissor lifts, 2 rubber bands, launch base, main gun, super sonic turret assembly, missile launcher, 6 rockets, 2 treads, 4 wheels, 4 missiles, flag, label sheet and instructions.

PLEASE FOLLOW THESE INSTRUCTIONS VERY CAREFULLY!

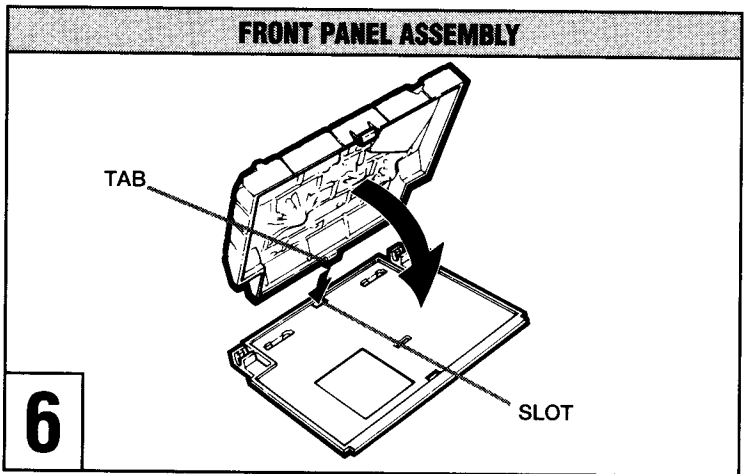
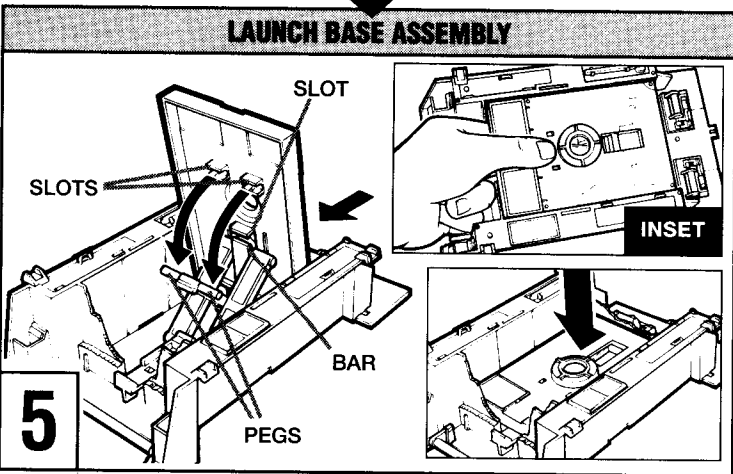
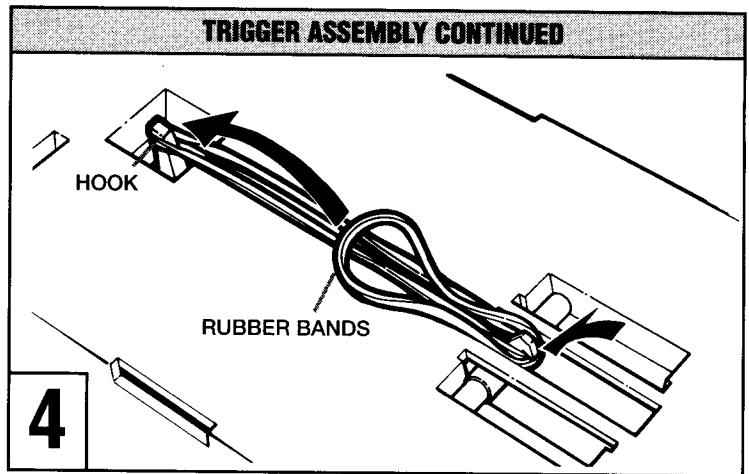
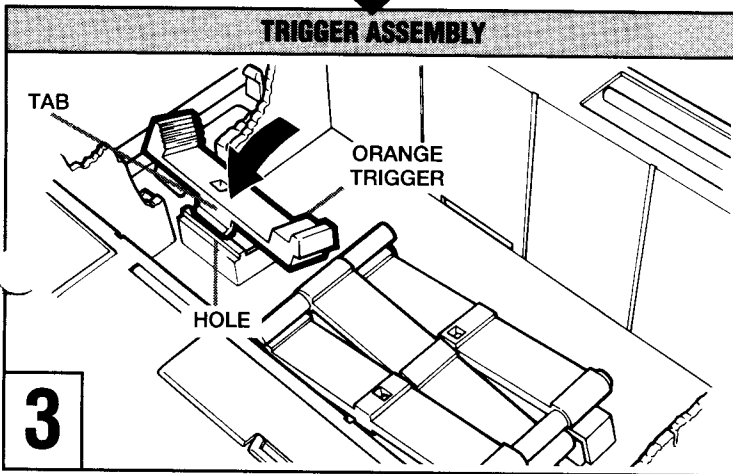
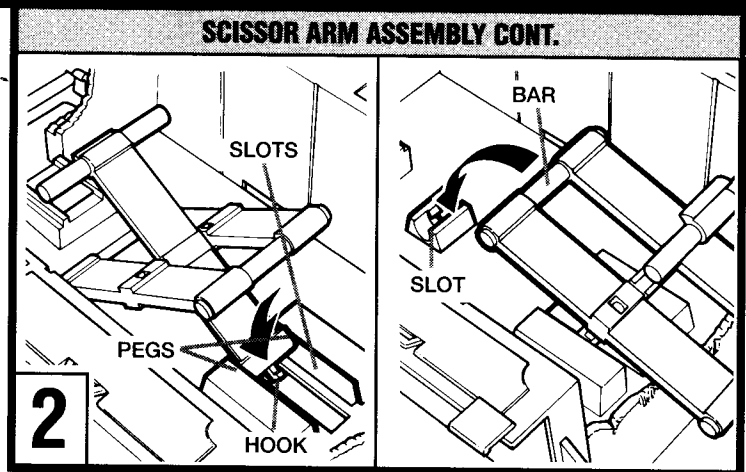
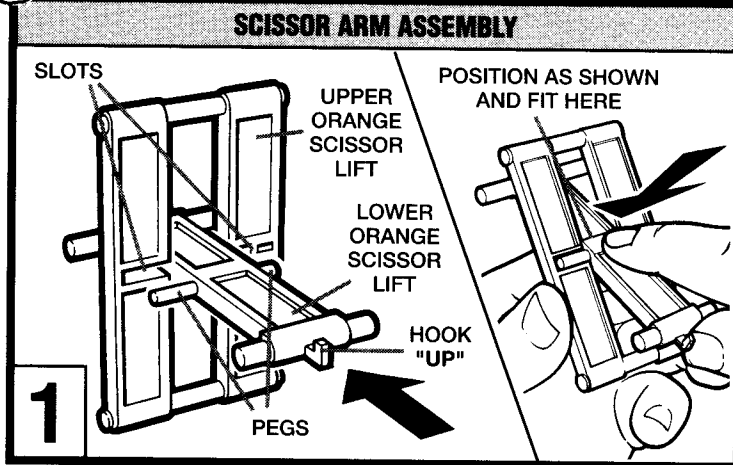

- 1 Fit lower orange scissor lift between sides of upper orange scissor lift as shown. Fit pegs on lower scissor lift into slots in upper scissor lift and hold together. (ILL. 1)
- 2 Fit pegs at end of lower scissor lift between front slots on the inside of green body. NOTE: Make sure hook at end of lower scissor lift is facing up as shown. Snap bar on upper scissor lift into slot in center of body. (ILL. 2)
- 3 Fit tab on one side of orange trigger into hole in rear center inside body. Snap trigger into place as shown. (ILL. 3)
- 4 Turn green body over and loop the two rubber bands onto the front and rear orange hooks extending from body bottom. (ILL. 4)
- 5 Slide bar on upper orange scissor lift into slot on bottom of green base. Position your fingers under pegs on top of lower orange scissor lift. Using your thumb, lower base onto scissor lift (INSET). Snap slots on bottom of base onto scissor lift pegs. **MAKE SURE PEGS ARE SNAPPED INTO BOTTOM OF BASE.** Push base down to lock in place. (ILL. 5)
- 6 Slide tab on top of brown front panel insert into slot in green front panel as shown. Snap front panel insert into front panel. (ILL.6)

FRONT HINGE ASSEMBLY

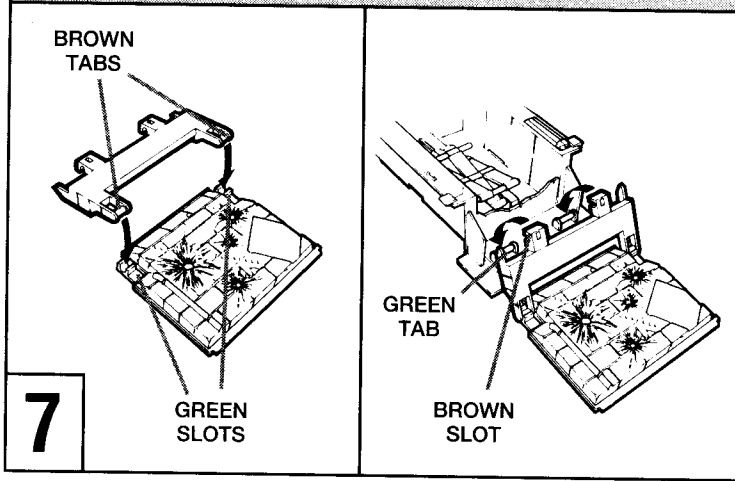

REAR PLATFORM ASSEMBLY

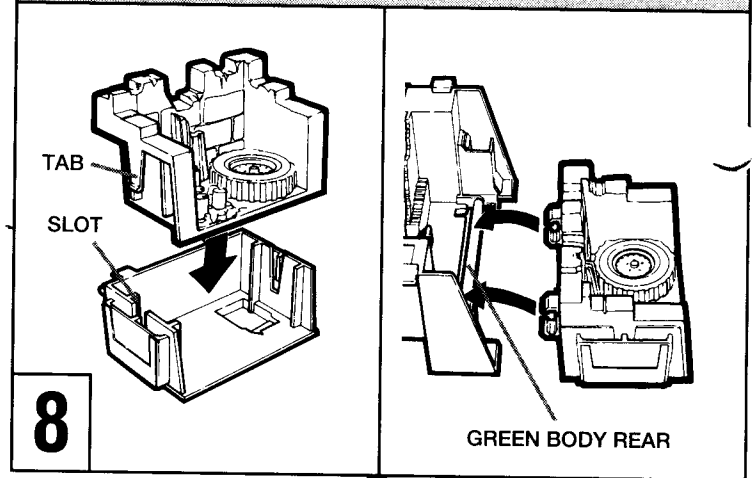

BODY WALLS ASSEMBLY

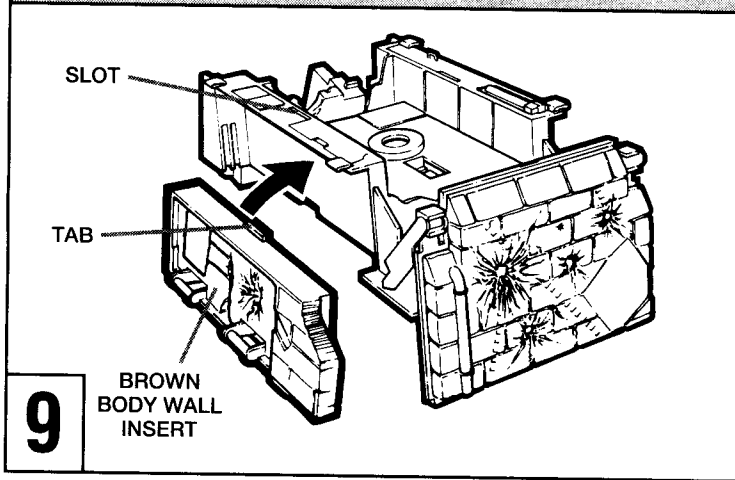

SIDE PANELS ASSEMBLY

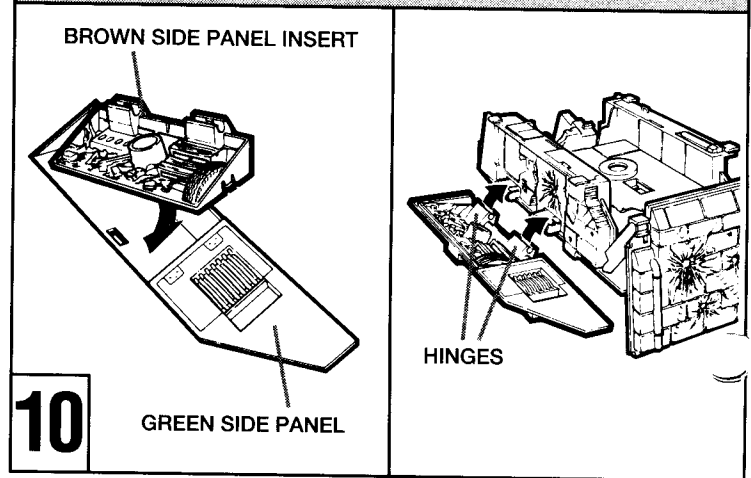

WHEEL/TREAD ASSEMBLY

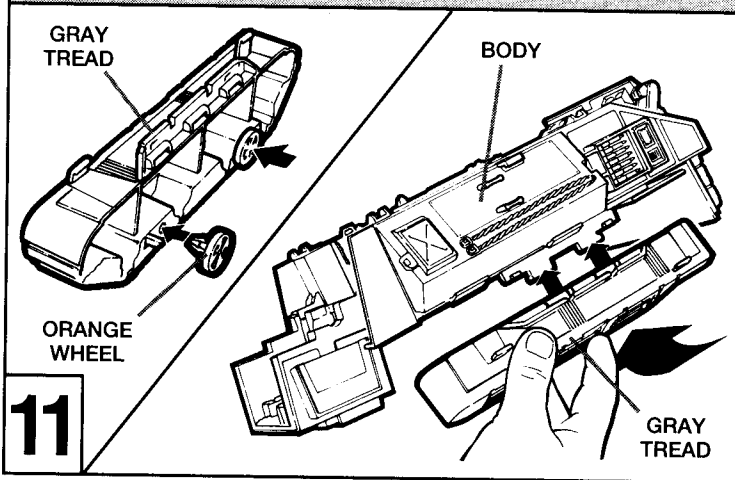

MISSILE LAUNCHER ASSEMBLY

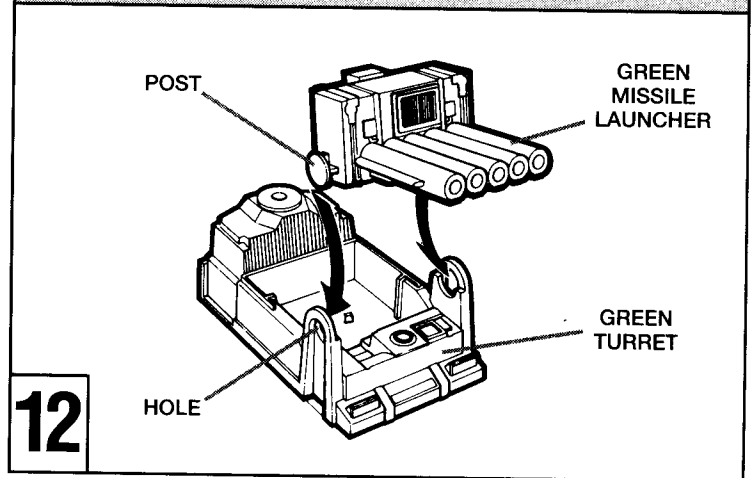

7 Snap tabs on brown front hinge into slots in green front panel. Snap slots on hinge onto tabs on front of green body. (ILL. 7)

8 Slide tabs on brown rear platform insert into slots in green rear platform base. Snap green tabs on back of platform onto bar at back of green body. (ILL. 8)

9 Snap tabs on right brown body wall insert (marked R) into slots in right green body wall as shown. Repeat for left side. (ILL. 9)

10 Snap right brown side panel insert (marked R) into right green side panel. Snap right side panel hinges onto body as shown. Repeat for left side. (ILL. 10)

11 Snap peg on orange wheel into hole in gray tread. Snap right tread (marked R) onto body, then fold tread up under body and snap into place. Repeat for left tread. (ILL. 11)

12 Snap posts on green missile launcher into holes in green turret. (ILL. 12)

TURRET ASSEMBLY

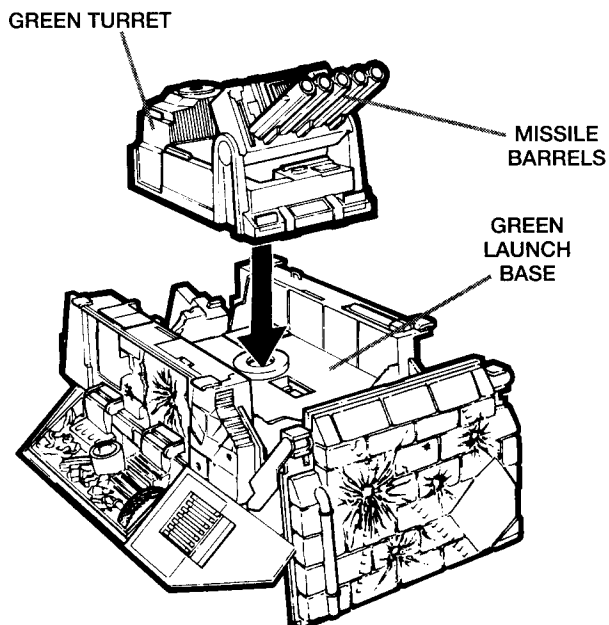

13

SONIC WEAPON/CANNON ASSEMBLY

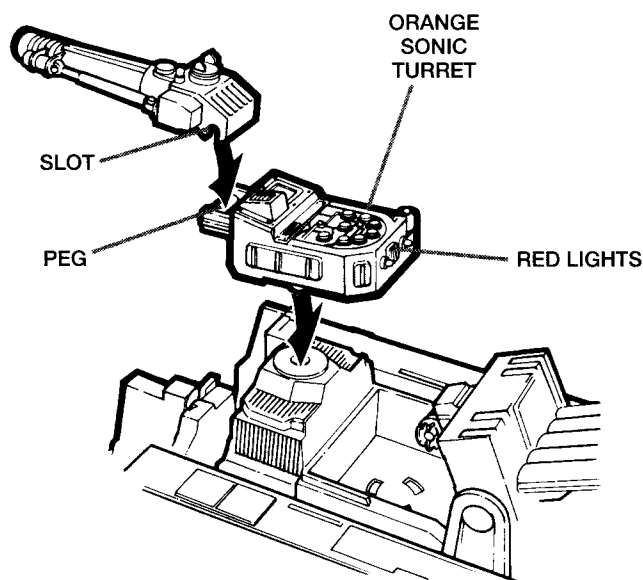

14

WEAPONS/FLAG STORAGE

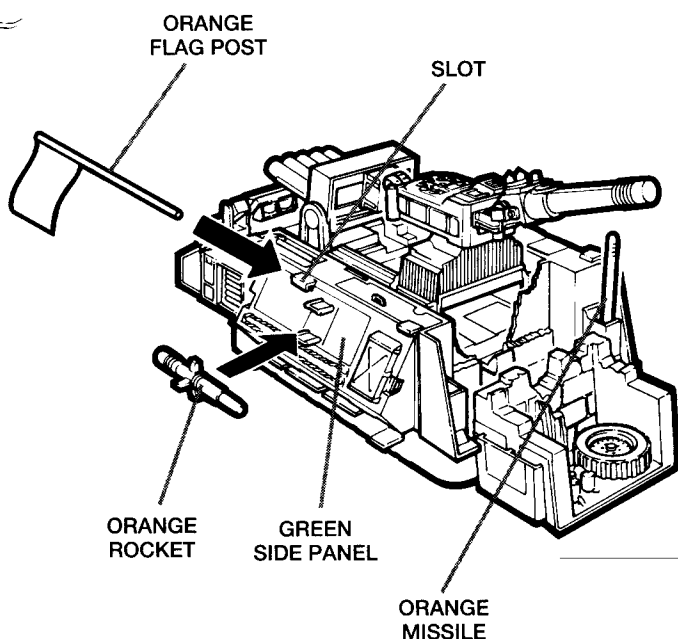

15

WEAPON FIRING

ORANGE TRIGGER IN UP POSITION TO LOAD MISSILES



ORANGE TRIGGER IN DOWN POSITION TO FIRE MISSILES

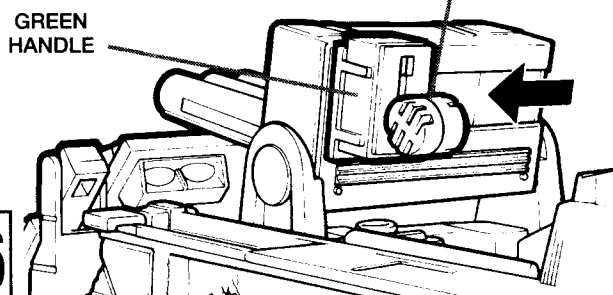

16

13 With missile barrels facing forward, snap green turret onto launch base. (ILL. 13)

14 With red lights on orange sonic turret facing green missile launcher, snap sonic turret onto green turret. Snap slots on end of orange cannon onto peg at front of sonic turret. (ILL. 14)

15 Fit orange rockets onto body. Insert orange flag post into slot on green side panel to store. Orange missiles can be stored in missile holders at back of body. (ILL. 15)

16 Place orange trigger in the "up" position and slide green handle to the right side of green missile launcher. Insert orange missiles into green missile barrels, stem first. To fire, push and lock trigger into "down" position and slide it all the way to the left. To reset trigger, repeat this step from the beginning. (ILL. 16) **Caution: Do Not Fire Missiles At Eyes Or Face.**

FORT AMERICA™

OFFICIAL G.I. JOE® VEHICLE SPECIFICATIONS

- 1) AMERICAN FLAG
- 2) ELECTRONIC LIGHTS AND SOUNDS MAIN BATTLE CANNON
- 3) SPRING-LOADED, "RIPPLE-FIRE" MISSILE LAUNCHER
- 4) FIVE SURFACE-TO-SURFACE MISSILES
- 5) FLIP-DOWN BODY SIDES REVEAL FORTRESS
- 6) FORT CONVERTS TO BATTLE-READY TANK
- 7) ROLLING WHEELS

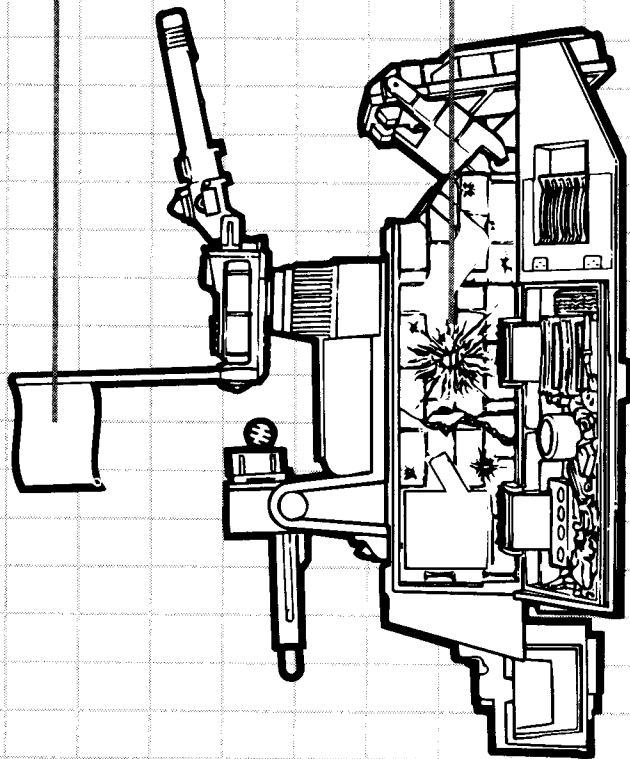
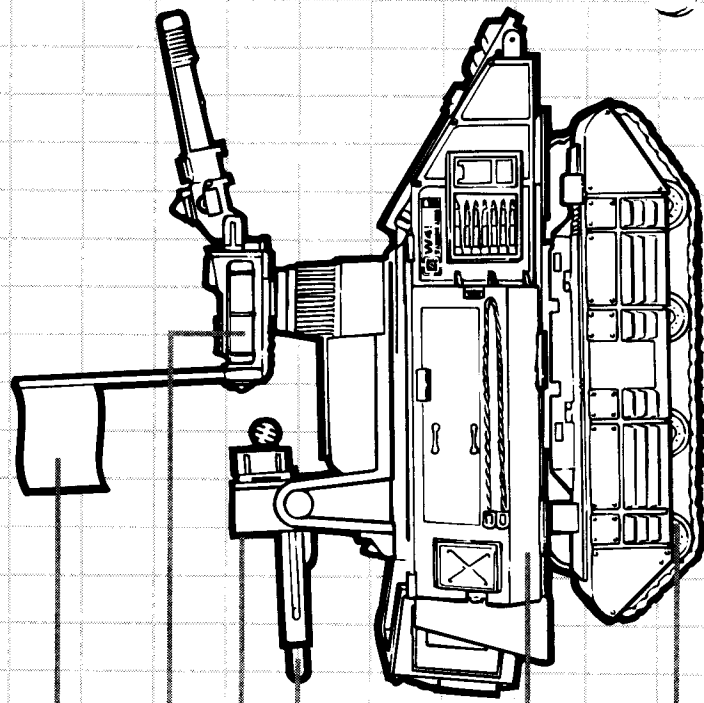
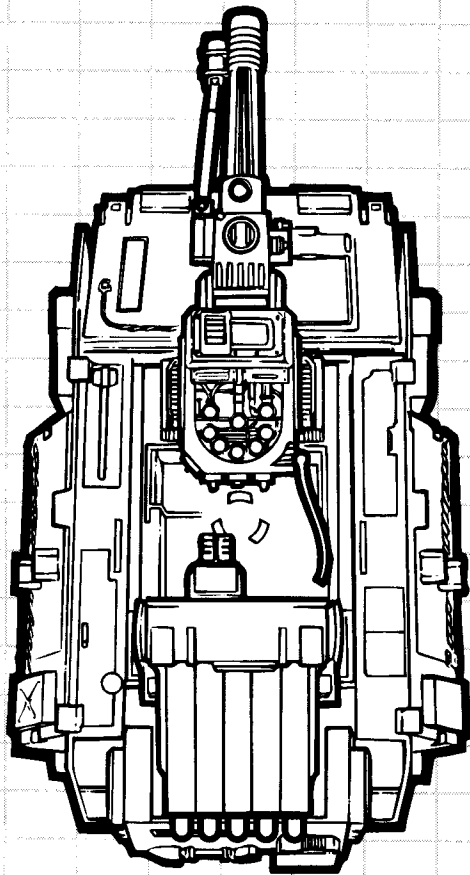

1
2
3
4
5
6

To convert your fortress into a mobile armored assault vehicle:

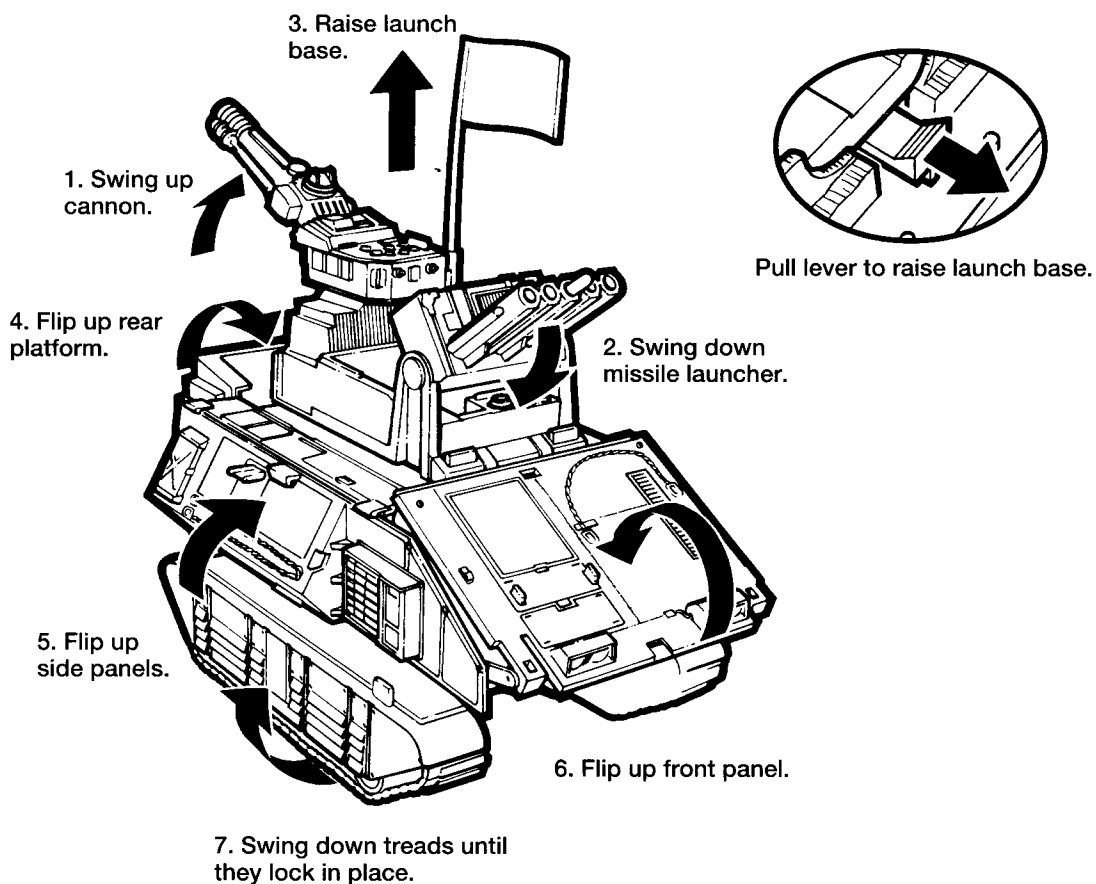

To convert your armored assault vehicle into a fortress:

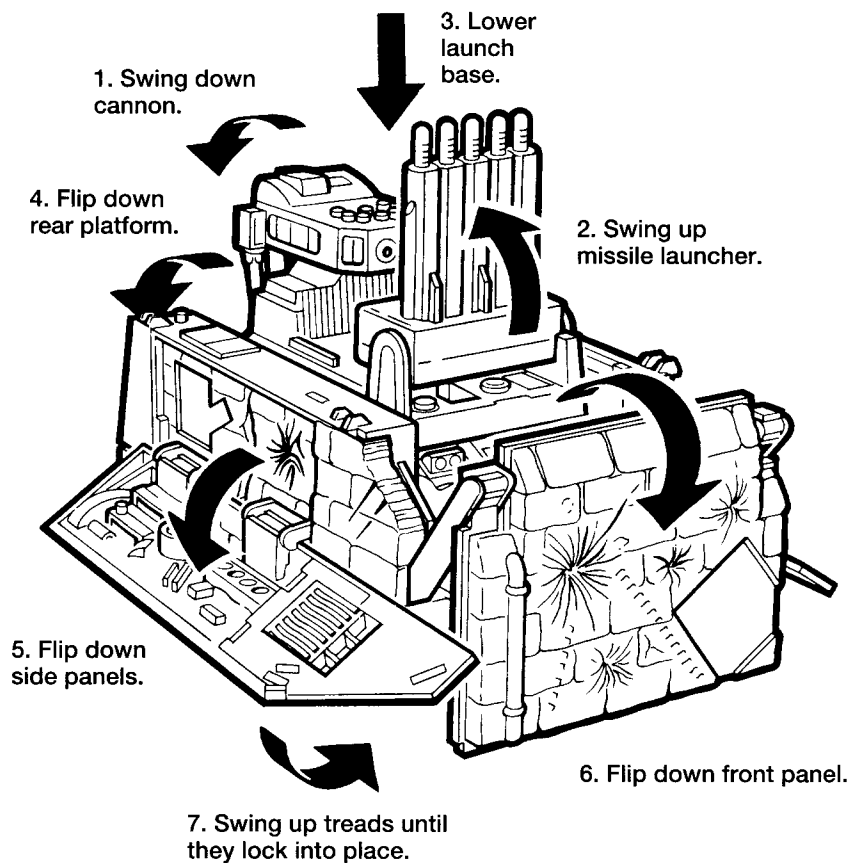

Peel and apply labels as shown.

UNITED STATES 10

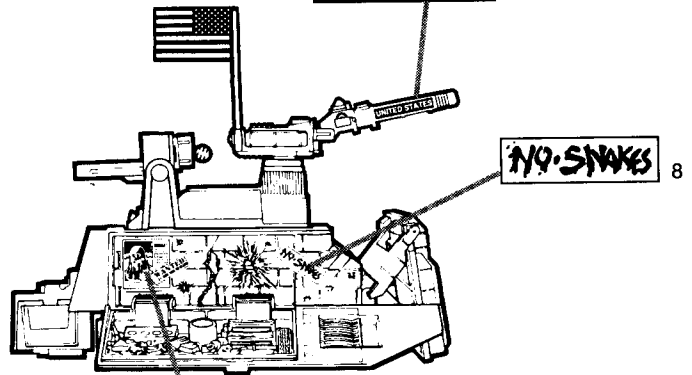
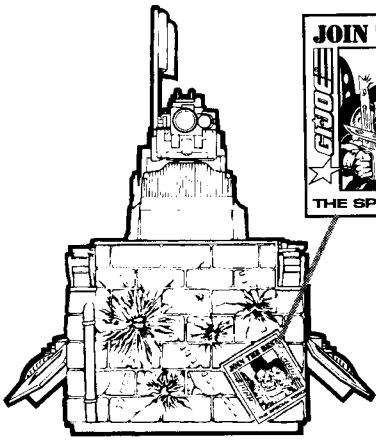

NO SNAKES 8



UNITED STATES 10

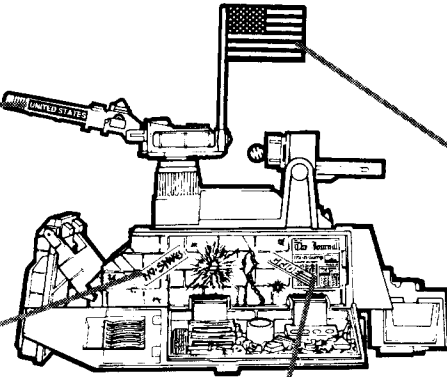

NO SNAKES 8



2

ONE LABEL ON EACH SIDE



9

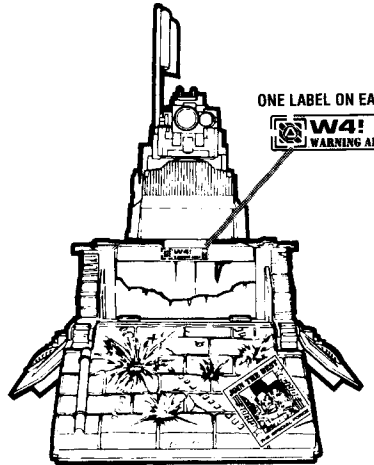

Joe's M.R.E. deli
WE DELIVER!

6



5



9

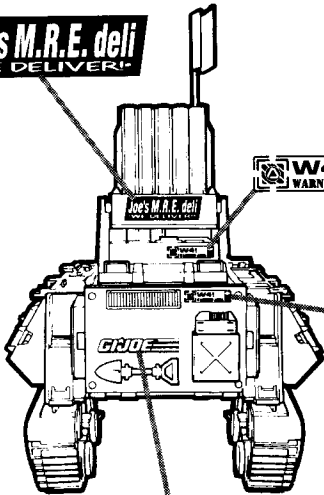

GI JOE 7



1

ONE LABEL ON EACH SIDE



11



ONE LABEL ON EACH SIDE

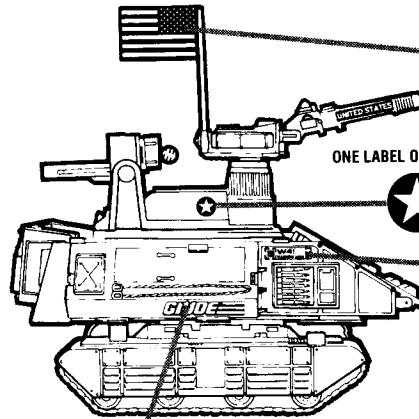

GI JOE 7

ONE LABEL ON EACH SIDE



9



11

GI JOE 7

7

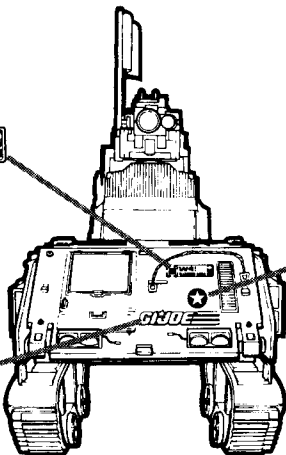

11

UNITED STATES 10

10

