

To Assemble HIGH SPEED ATTACK VEHICLE:

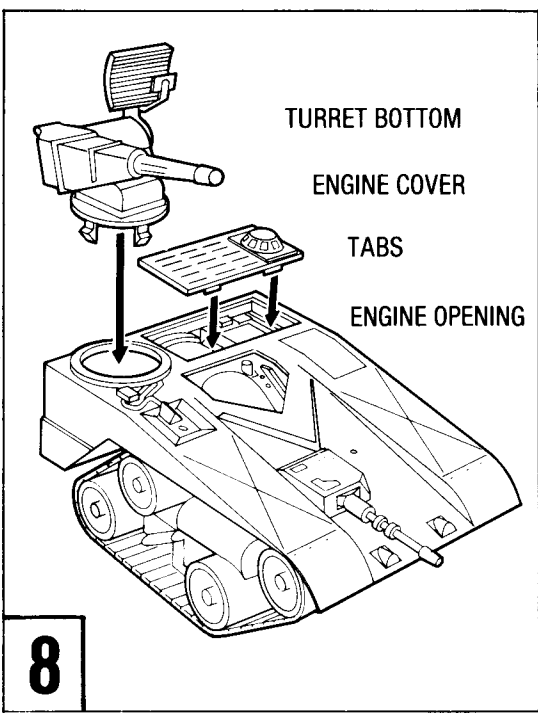

- 1** Fit Right Front track (marked RF) over posts on right side of Attack Vehicle chassis. (ILL. 1)
- 2** Turn chassis over. Insert 2 axles into holes in Right Front track. Place Left Front track (marked LF) over chassis and axle posts. (ILL. 2)
- 3** With posts on front hinge joint facing inside of chassis, fit one post into hole in rear of chassis. (ILL. 3)
- 4** Turn Attack Vehicle body top over. Insert gun barrel through slot and fit onto post. (ILL. 4)
- 5** Place front slots in body top over tabs on chassis. Making sure hole in body top lines up with hinge joint post, snap rear tabs into place. (ILL. 5)
- 6** Place laser gun bar onto turret bottom. (NOTE: Make sure gun is on flat side of turret.) (ILL. 6)
- 7** Line up large tab on turret top with large notch on turret bottom. Snap together. Snap radar dish into radar mount. (ILL. 7)
- 8** Snap turret bottom into vehicle. Fit tabs on engine cover into slots in engine opening and snap closed. (ILL. 8)

To Assemble BATTLEFIELD CONTROL VEHICLE:

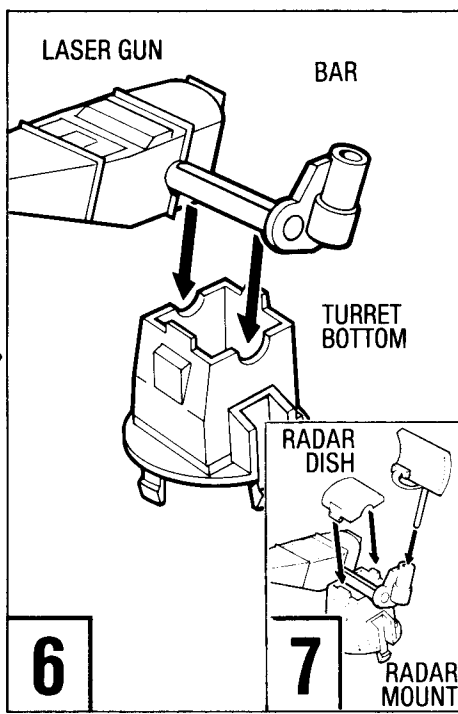
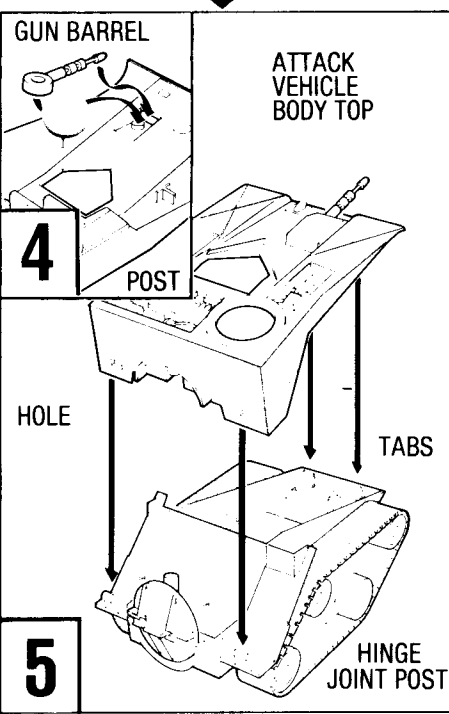
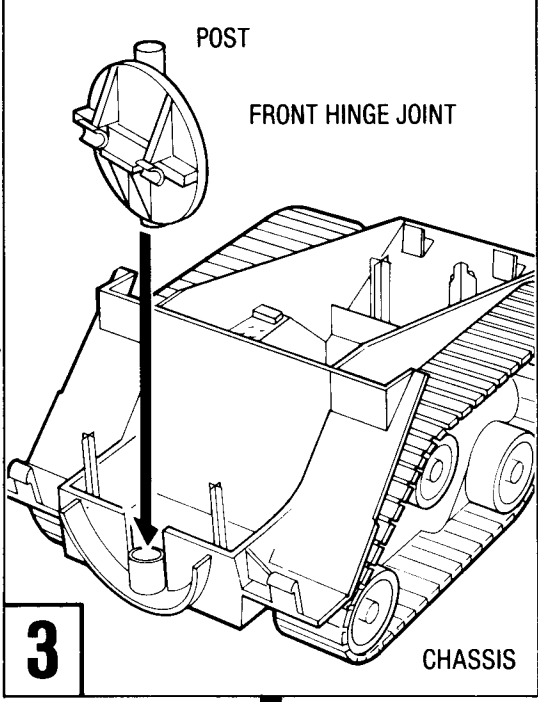
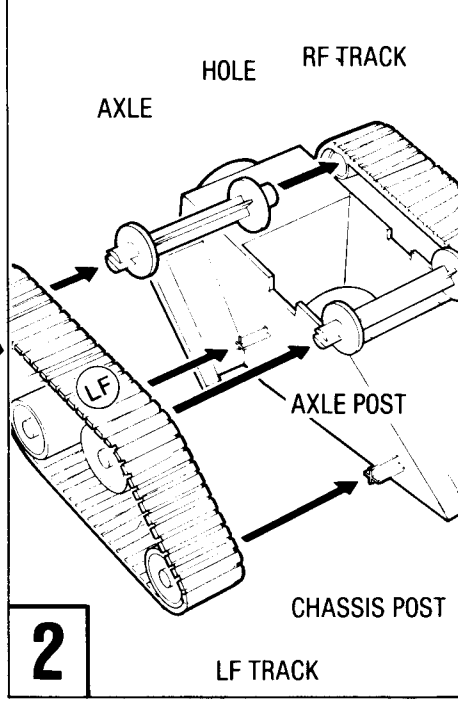
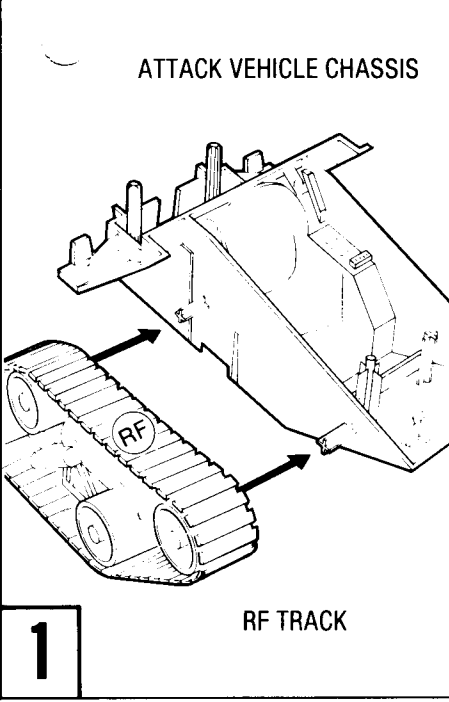
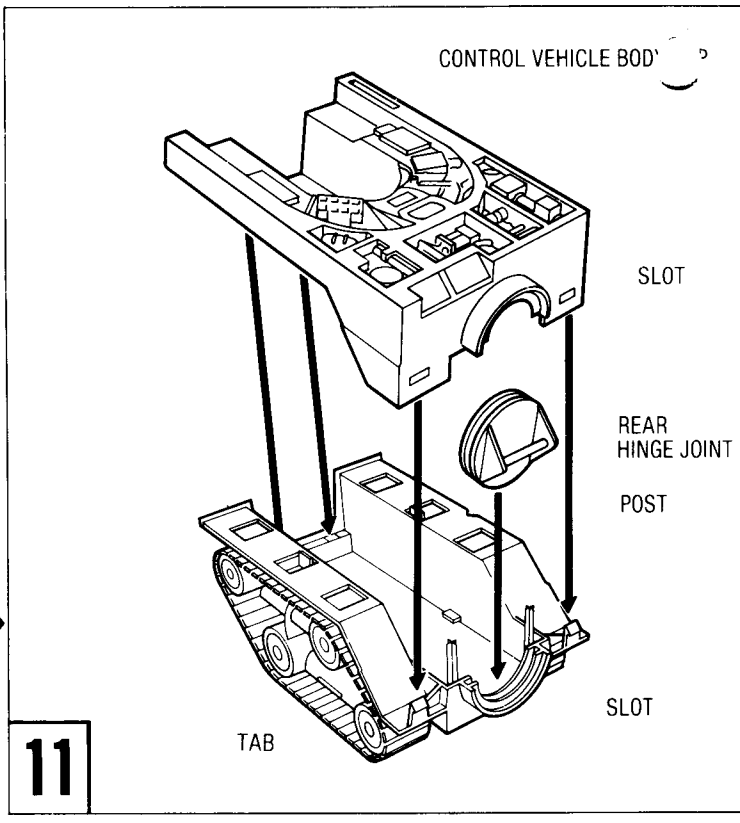
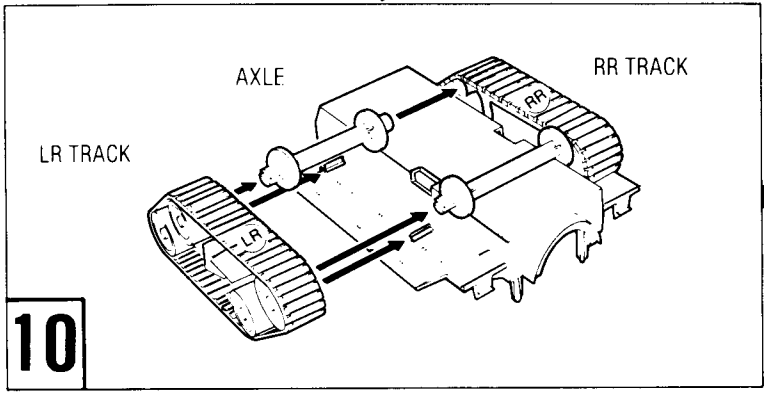
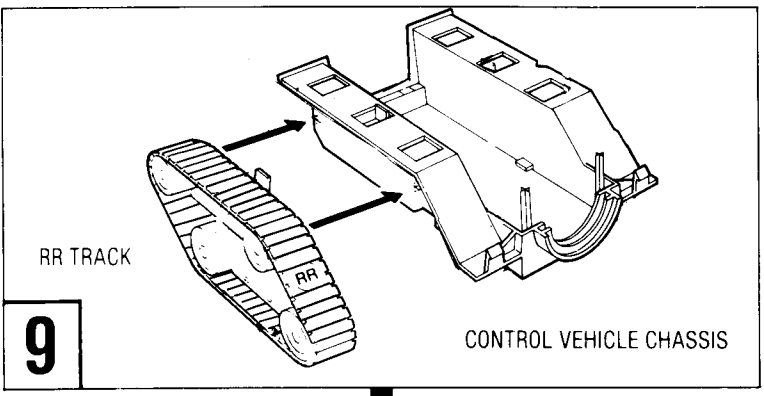

- 9** Fit Right Rear track (marked RR) over posts on right side of Control Vehicle chassis. (ILL. 9)
- 10** Turn chassis over. Insert 2 axles into holes in Right Rear track. Place Left Rear track (marked LR) over chassis and axle posts. (ILL. 10)
- 11** Turn chassis right side up. With post facing outwards, fit rear hinge joint into slot in chassis. Place Control Vehicle body top over chassis, making sure slot lines up with hinge joint. Snap front and rear tabs into place. (ILL. 11)

To Assemble GUN EMPLACEMENT:

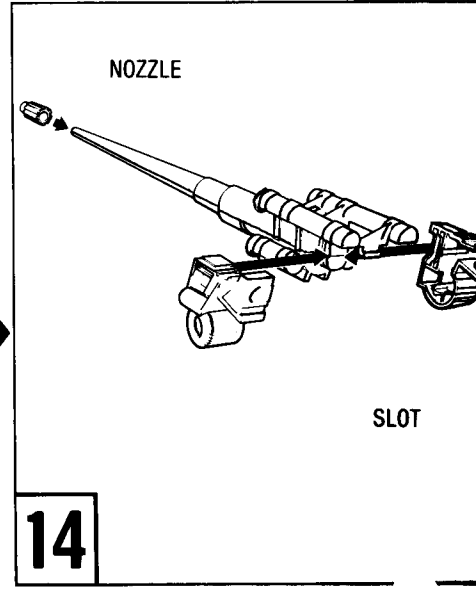
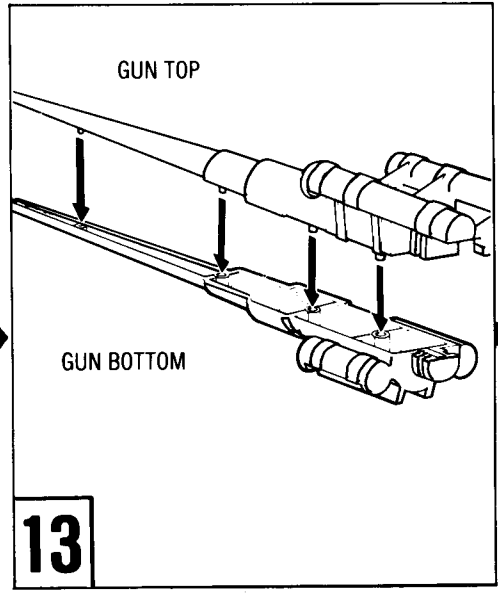
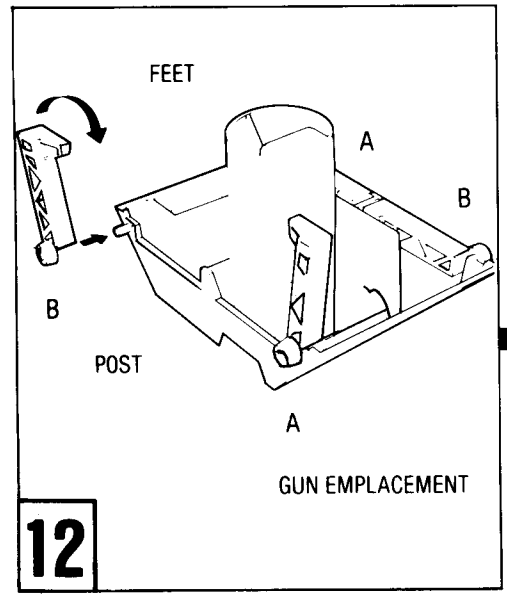

- 12** Turn Gun Emplacement over. With feet facing inward, snap legs over posts on Gun Emplacement. Fold legs in. (ILL. 12)
- 13** Fit posts on gun top into holes in gun bottom. (ILL. 13)
- 14** Press nozzle onto tip of barrel. Line up slots in right gun mount with end of gun barrel. Repeat with left gun mount. Firmly press gun mounts together. (ILL. 14)

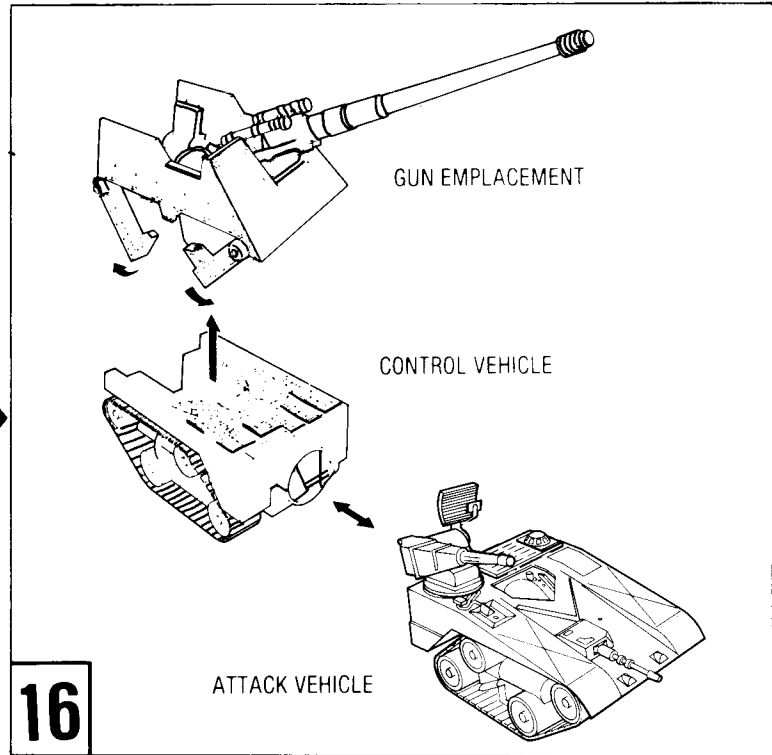
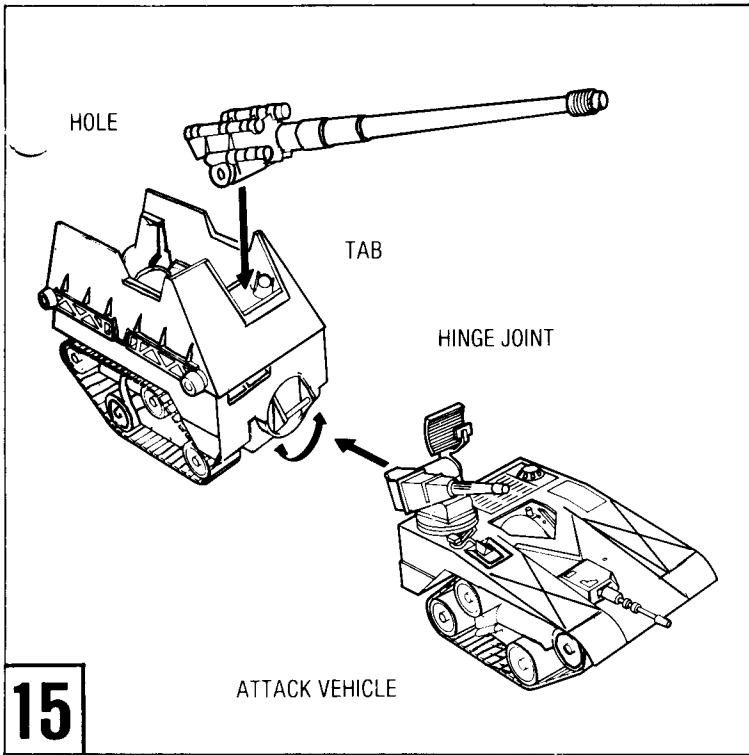

- 15** Snap gun mount holes over tabs in Gun Emplacement. Snap tabs on Attack Vehicle hinge joint over post on Control Vehicle hinge joint. (Hinge joint articulates for extremely rough terrain!) (ILL. 15)
- 16** The mobile attack unit turns into 3 separate battle units! Lift off the Gun Emplacement unit and flip legs down, then separate Control Vehicle and Attack Vehicle Hinge joints. You have three vehicles in one! (ILL. 16)

Apply your official battle insignias, refer to the diagram below.

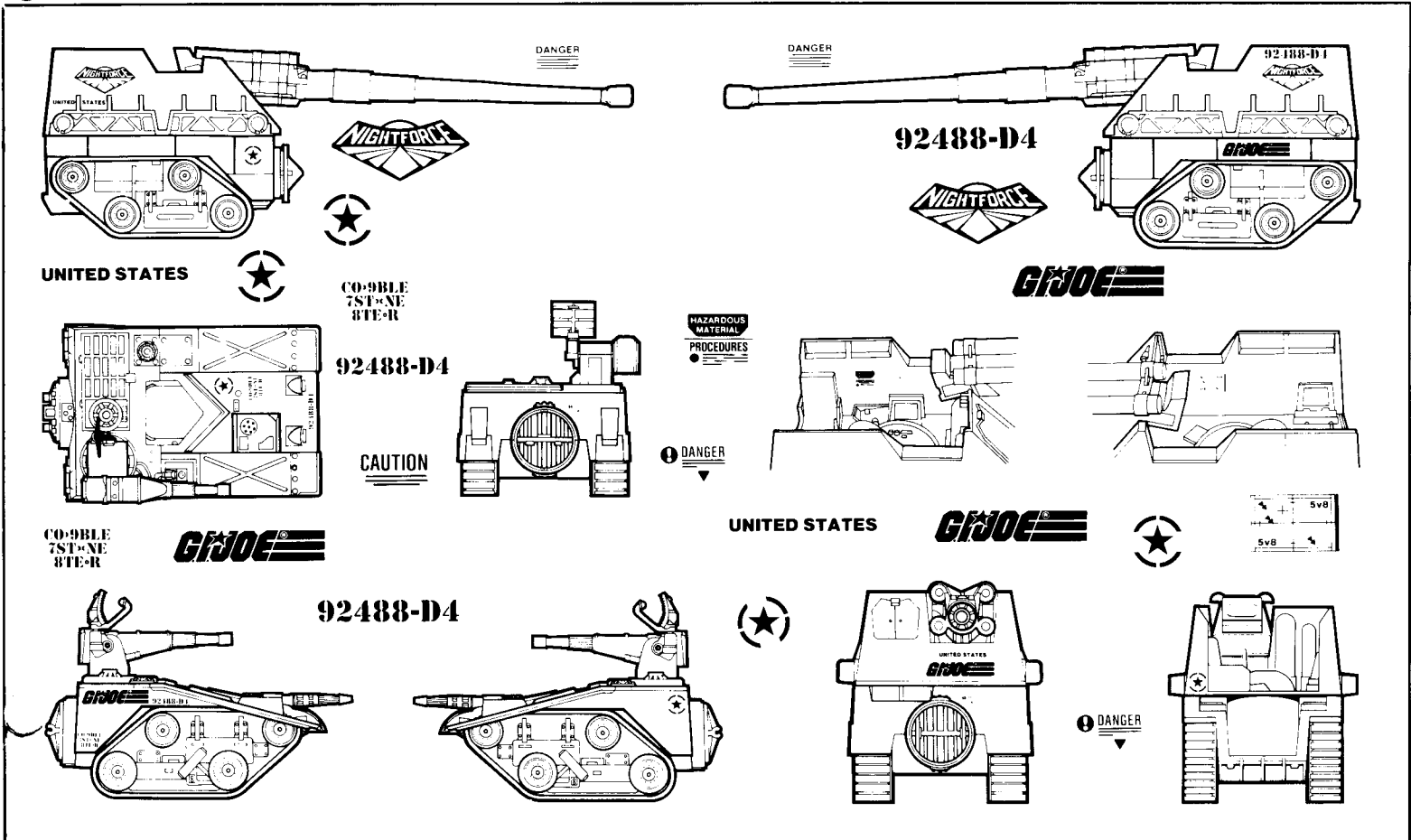

NIGHT BLASTER™

- 1) "NIGHT VISION" MAG-61V GYRO-COMPUTING RADAR
- 2) ROTATING DRIVER-OPERATED 240RPM 40MM CANNON
- 3) "QUIET SHOT" ULTRA NOISE-DAMPENING MUZZLE
- 4) "SILENT SPEED" SEPARATING ARMOR ANTI-TANK VEHICLE (ATV)
- 5) "HEATER" (HIGH EFFICIENCY ANTI-TANK ENERGY REACTOR) LASER
- 6) "RAP" (ROCKET ASSISTED PROJECTILE) LONG RANGE 155MM CANNON)
- 7) ATV DRIVER COMMAND SEAT
- 8) SUPER QUIET "NO NOISE" 1000HP DOUBLE MUFFLER DIESEL ENGINE
- 9) HYDRO-PNEUMATIC ARTICULATION AND SEPARATION JOINT
- 10) HYDRAULICALLY-OPERATED CANNON HOUSING SUPPORT ARMS
- 11) LATERAL ENERGY DISPERSION PROTECTION ARMOR
- 12) ARMORED RECONNAISSANCE VEHICLE (ARV)
- 13) HYDRO-PNEUMATIC VARIABLE RECOIL CANNON SUPPORTS
- 14) BATTLEFIELD FIRE CONTROL STATION
- 15) STATIONARY ARMORED COMMAND POST

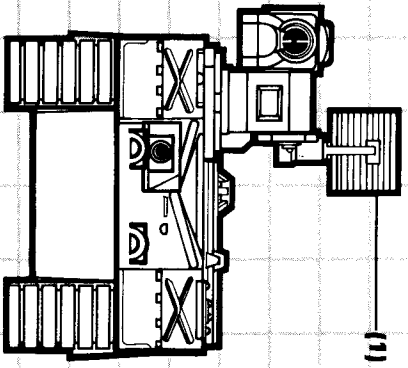

(11)

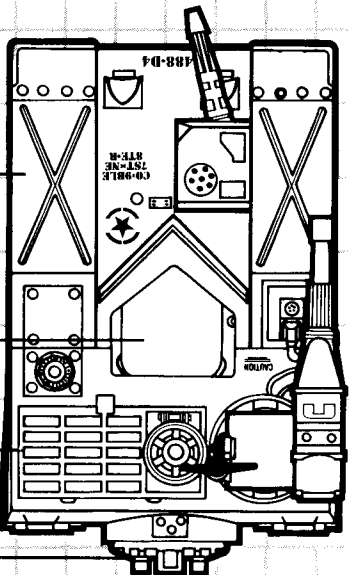

(3)

(4)

(6)

(7)

(8)

(9)

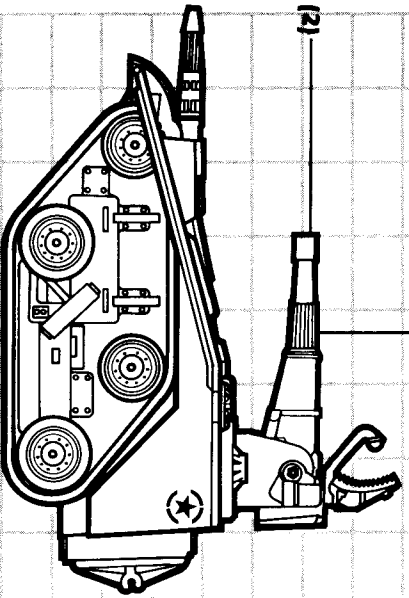

(5)

(2)

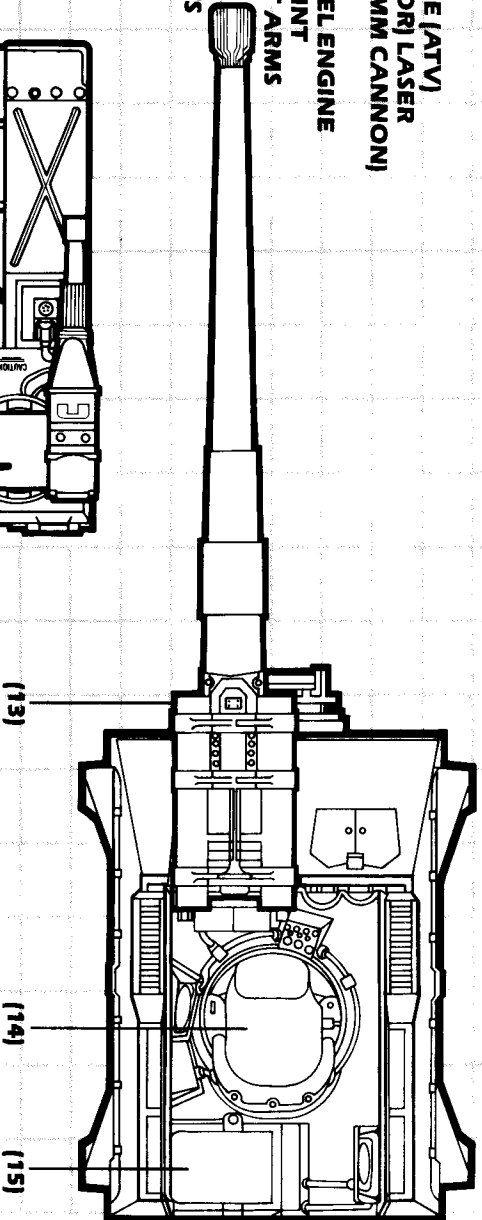

(13)

(14)

(15)

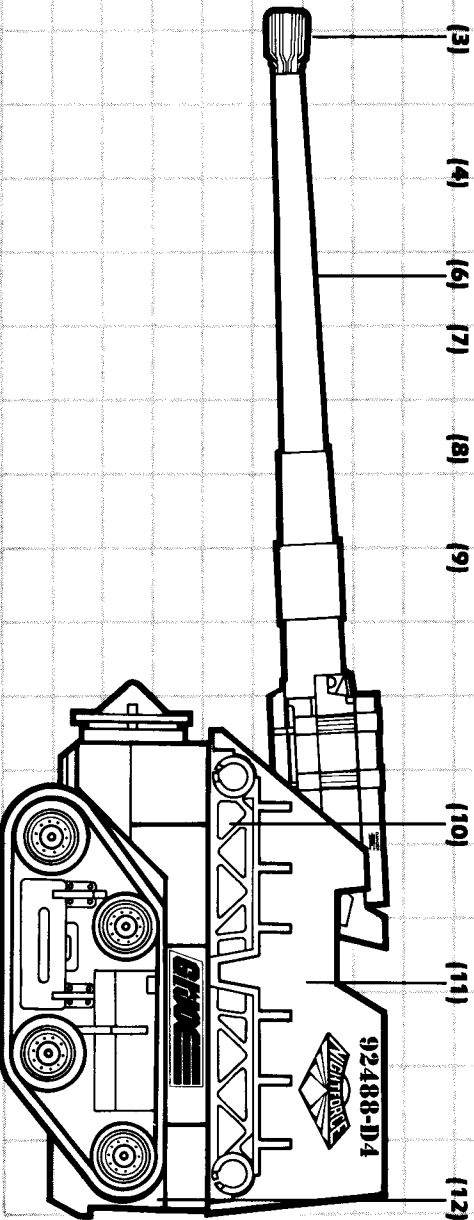

(10)

(11)

(12)

92488-D4

NIGHTFORCE