

For Easy Assembly, Match The Numbered Runner Frame Parts With Those Called Out In The Instructions.

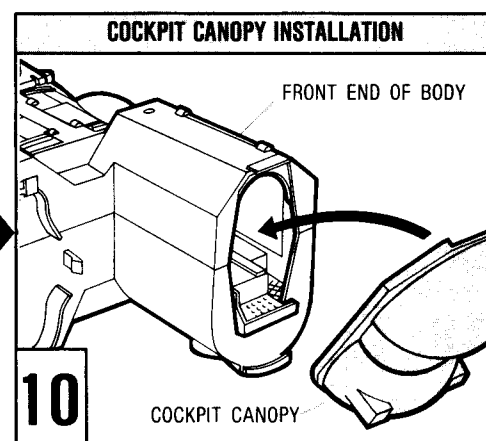

1. Snap large interior over posts in body bottom. (ILL. 1)
2. Snap front wheel axles together (those with indentations) (Part #7). Snap rear wheel axle together. (Part #8) (ILL. 2)
3. Press hand against interior and snap post on wheel axles onto holes in bottom of body. Be sure to use both hands and snap axle post into holes one at a time. Also be sure the axle posts are inserted through the holes in the interior. (ILL. 3)
4. Snap permanent end of seat belt into hole in left side of seats. Then, snap adjustable end of seat belt into right side of seat. Turn body bottom right side up. Snap cockpit interior into front end of body bottom. (ILL. 4)
5. Snap tabs on body top with holes in body bottom and snap together. (ILL. 5)
6. Snap tab on front door into holes in front door opening. Snap side door into side opening. Repeat for door on other side of body. (ILL. 6)
7. Snap rear door into rear opening. (ILL. 7)
8. Fit right jet top onto right body side. Repeat process for left jet top. (NOTE: Be sure hand pegs on jet top are facing forward.) (ILL. 8)
9. Snap front jet intake onto front end of right jet assembly. (Part #20). Snap left jet exhaust onto left jet assembly. (Part #21). Repeat process for right jet assembly. (ILL. 9)
10. Snap cockpit canopy onto front end of body. (ILL. 10)

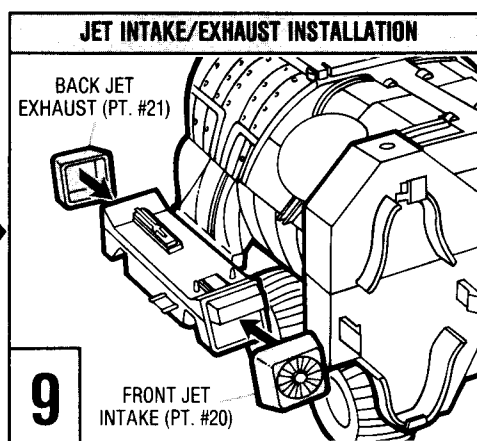
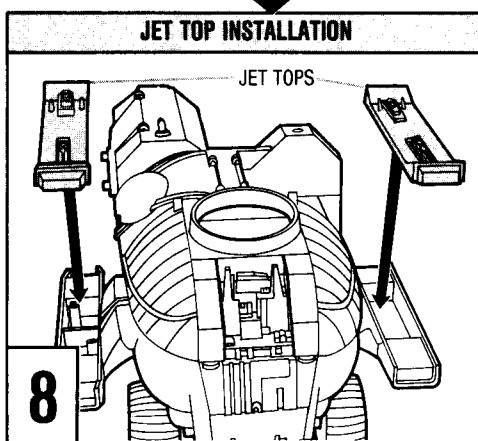
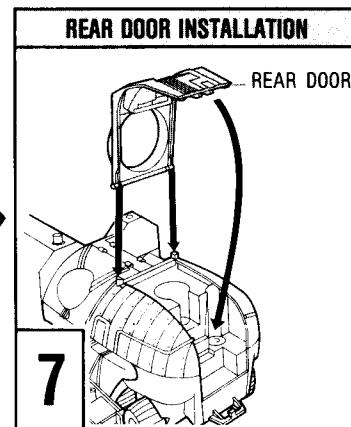
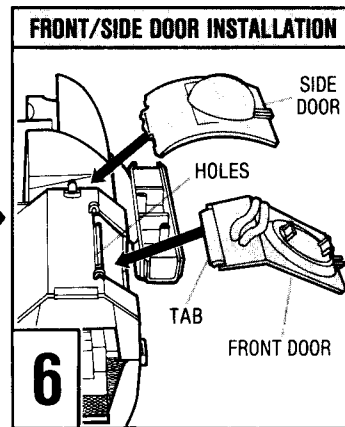
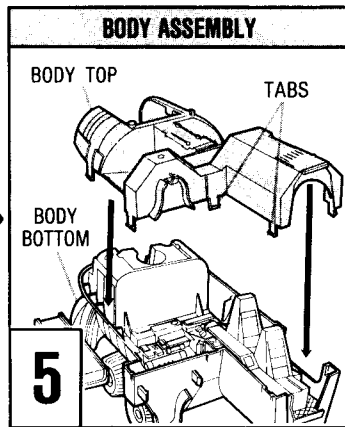
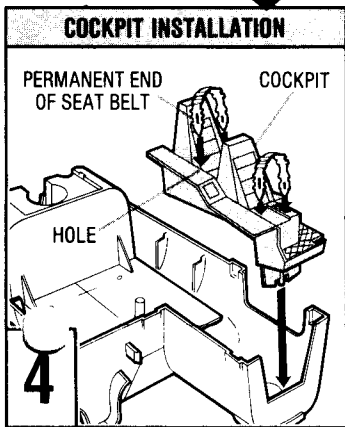
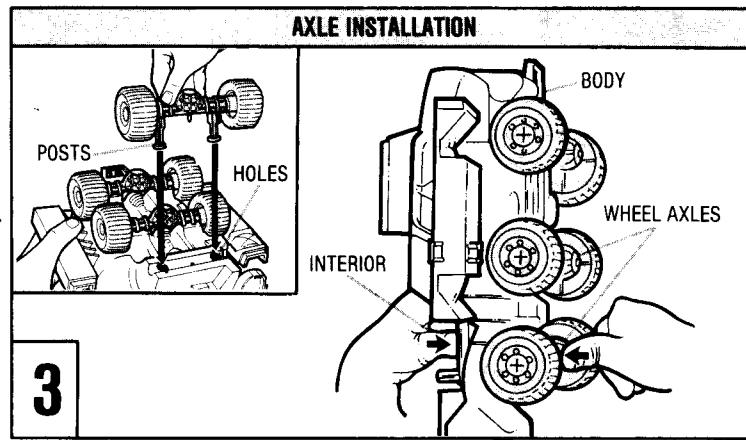
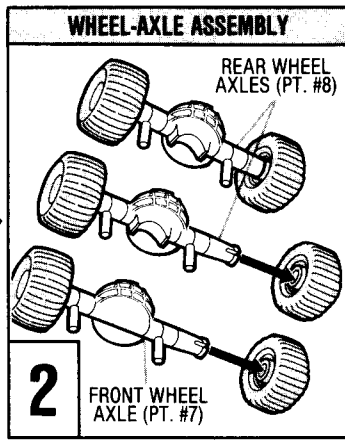
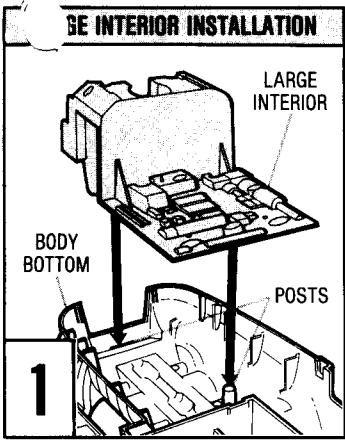
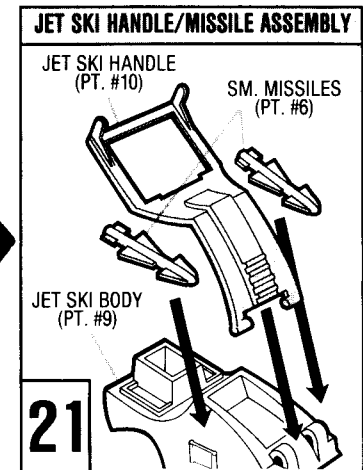
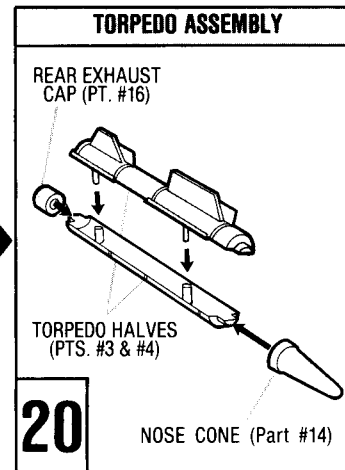
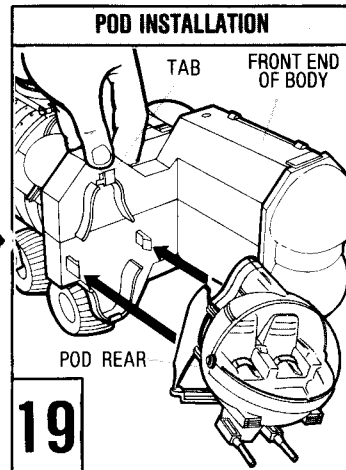
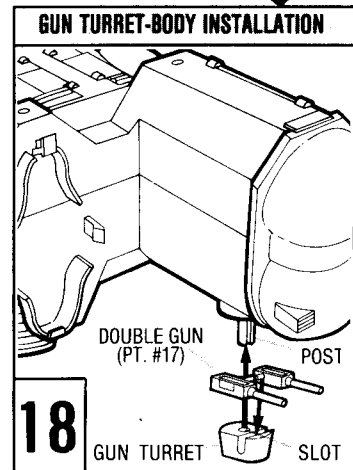
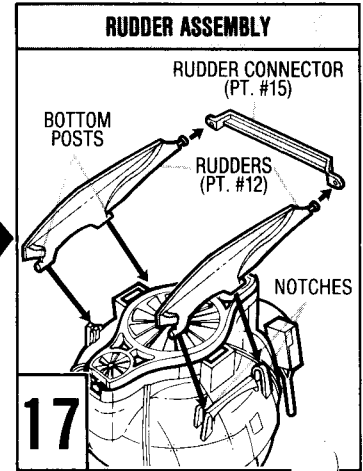
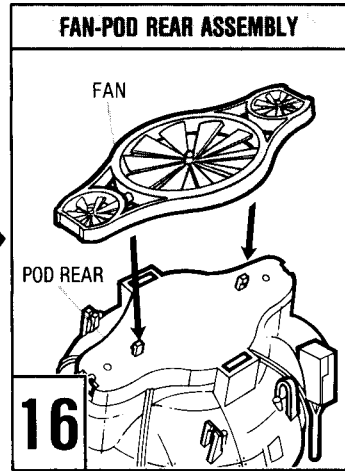
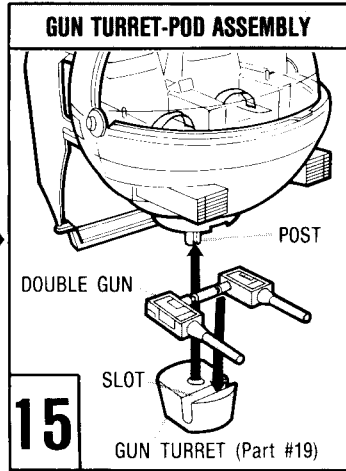
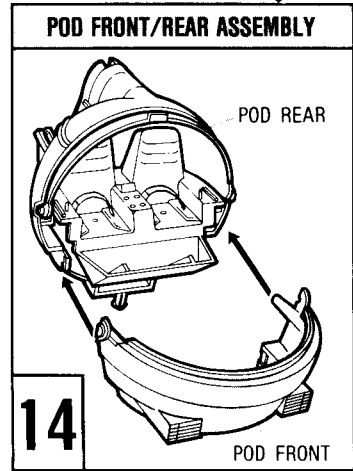
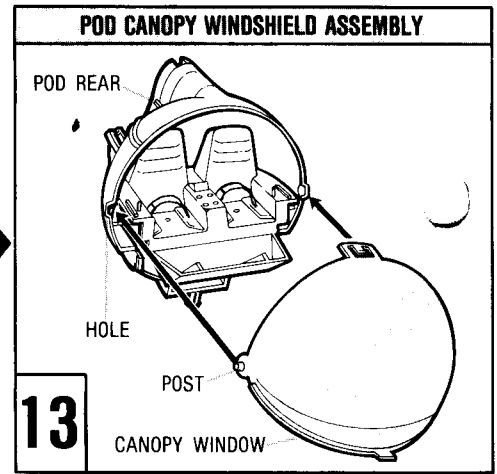
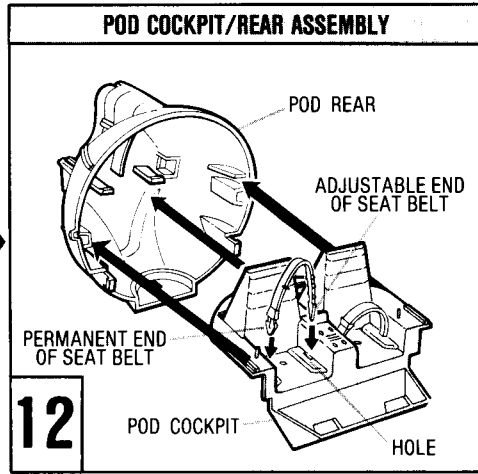
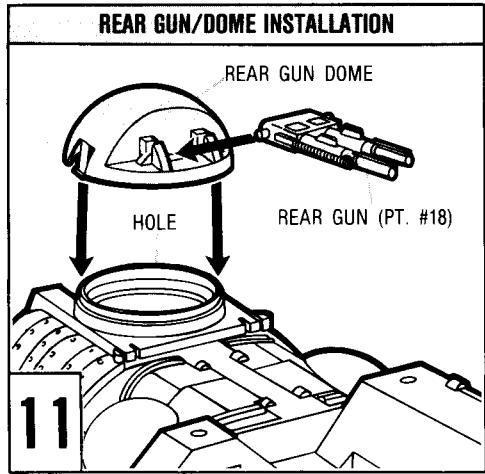

11. Snap rear gun dome over hole in body top. Snap rear gun into rear gun dome. (Part #18). (ILL. 11)
12. Snap permanent end of seat belt into hole in left side of seats. Then, snap adjustable end of seat belt into right side of seat. Slide submarine pod cockpit section into pod rear and snap into place. (ILL. 12)
13. Snap posts on canopy window into holes in sides of pod rear, then slide into back of canopy. (ILL. 13)
14. Snap pod front into pod rear. (ILL. 14)
15. Snap double gun into slot of gun turret (Part #19), then snap gun turret onto post on pod. (ILL. 15)
16. Snap fan onto pod rear. (ILL. 16)
17. Snap rudders into notches in pod rear (Part #12). Snap rudder connector onto bottom posts on rudders (Part #15). (ILL. 17)
18. Snap double gun into slot of gun turret, then snap gun turret onto post underneath front end of body. (Part #17). (ILL. 18)
19. Hook bottom of pod rear onto front end of body, then swing up top of pod rear and snap onto front end of body. (NOTE: Depress thumb tab to release submarine pod from body.) (ILL. 19)
20. Fit torpedo halves together. (Part #3 & #4). Snap nose cone onto front end of torpedo. (Part #14). Snap rear exhaust cap onto rear of torpedo. (Part #16). Repeat process for other torpedo. (ILL. 20)
21. Snap jet ski handle onto front of jet ski body. (Part #'s 9 & 10). Repeat process for other jet ski. Fit (2) small missiles onto jet ski as shown. (Part #6). Repeat process for other jet ski. (ILL. 21)

JET SKI INSTALLATION

JET SKI

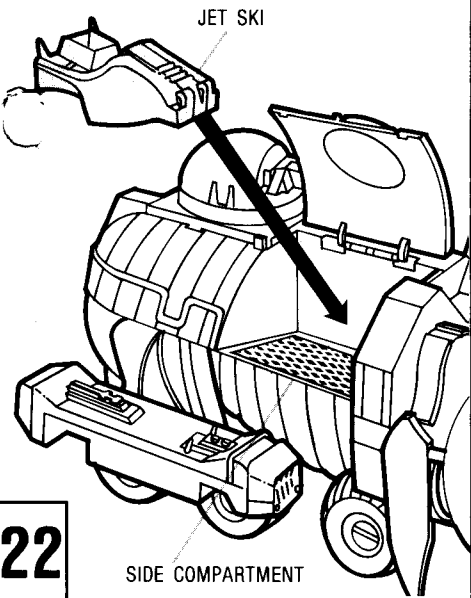

22

SIDE COMPARTMENT

GENERAL MISSILE INSTALLATION

TAB

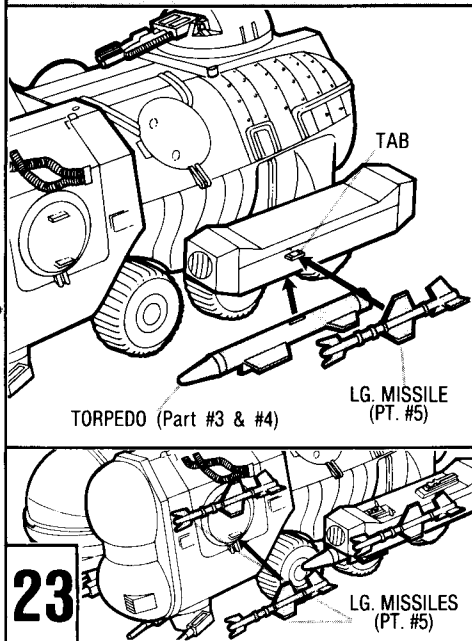

23

TOP GUN/MOUNT INSTALLATION

TOP GUNS (PT. #11)

HOLE

GUN MOUNT (PT. #13)

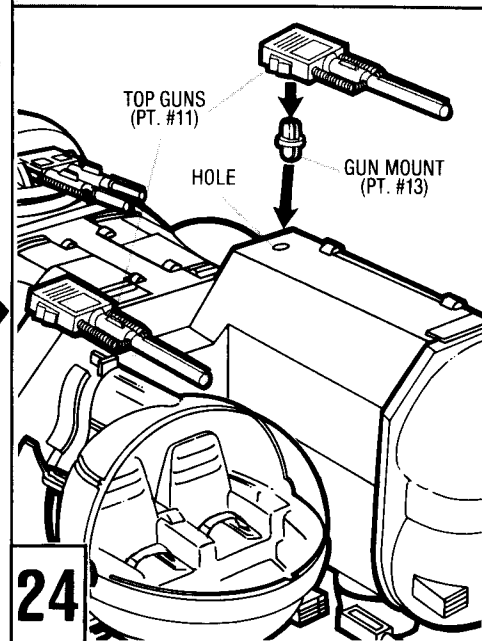

24

- 22. Snap jet ski into right side compartment. Repeat for other jet ski. (ILL. 22)
- 23. Fit (2) large missiles onto front door. Fit torpedo underneath left jet. Fit large missile onto side of left jet (Part #5). Repeat process for right jet. (INSET) Fit one large missile and one small missile onto cockpit front door as shown. (ILL. 23)
- 24. Snap gun mounts into hole in body top (Part #13). Snap top gun onto gun mount on body top (Part #11). Repeat for other top gun. (ILL. 24)

Peel and apply labels as shown.

699727 Bugg

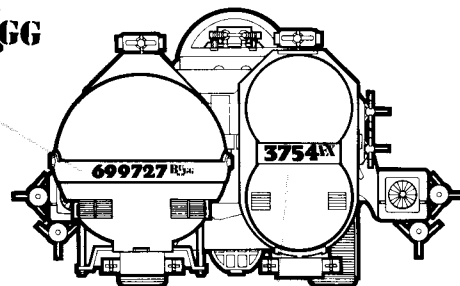

27

3754X

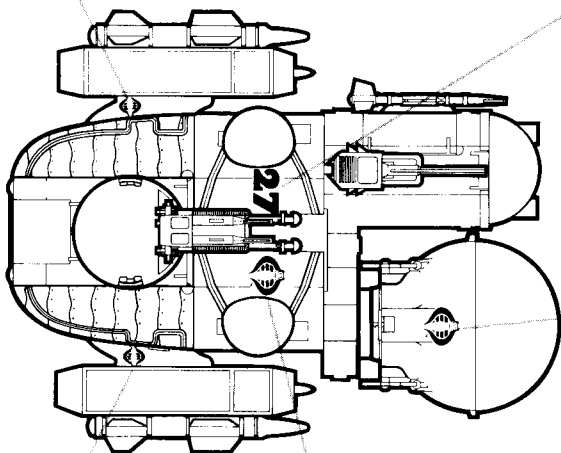

THIS LABEL APPEARS IN SAME LOCATION ON OPPOSITE SIDE.



27

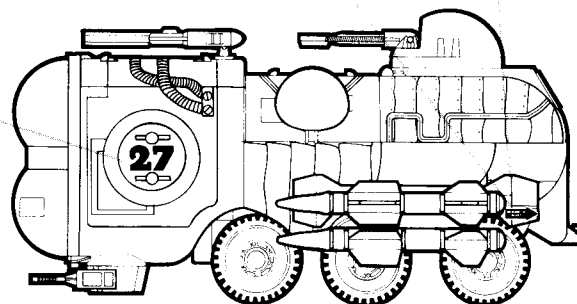

B.U.G.G.™

1. PRESSURIZED/WATERTIGHT TWO-MAN COCKPIT
2. UNDERSEA PRESSURE TESTED BALLISTIC PROOF CANOPY
3. SEAMLESS "FLEX" SKIN POD BODY
4. BORON-EPOXY DIRECTIONAL VANES
5. "DOUBLE BUBBLE" PRESSURIZED DRIVER CANOPY
6. FT. 109 "FORKED TONGUE" SURFACE-TO-AIR SIDE MOUNTED MISSILE
7. SINGLE BARREL .50 CALIBER AUTO-LOAD ROTATING MACHINE GUNS
8. FLOATATION/DESCENT AIR TANK PURGE VENTILATORS
9. SIDE HATCH COMPARTMENT DOOR/HOVER SKI ACCESS PLATFORMS
10. SIDE MOUNTED EXTERIOR HORIZONTAL POSITION PERSONNEL PLATFORMS

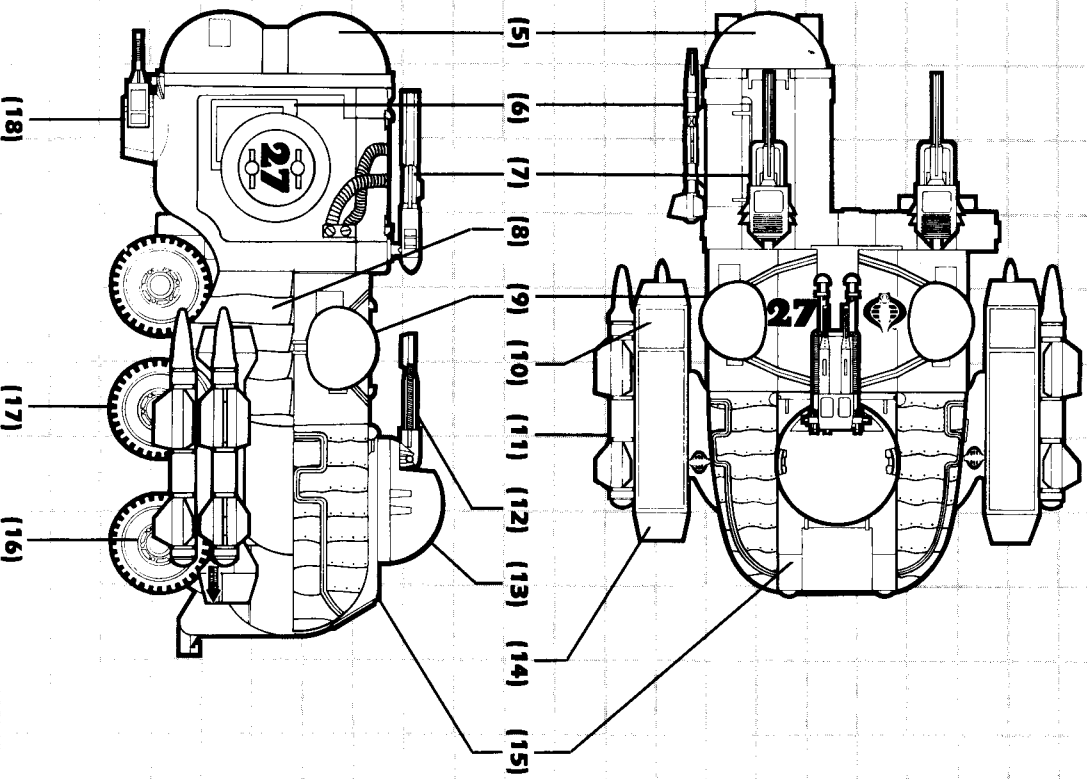

11. "STRIKE" VT-60 FLOW-THROUGH DESIGN ALCOHOL POWERED TORPEDO
12. REAR-MOUNTED DUAL BARREL .50 CALIBER ROTATING MACHINE GUN
13. LOW PROFILE BALLISTIC DEFLECTION MACHINE GUN CANOPY
14. EXTERNAL GAS TURBINE UNDERWATER PROPULSION UNITS
15. REAR MOUNTED ARMORED PERSONNEL ACCESS HATCH
16. NON-CLOGGING THREE PIECE MODULAR STAINLESS STEEL WHEELS
17. ALL-TERRAIN PUNCTURE-PROOF AUTOMATIC INFLATION ADJUST TIRES
18. SINGLE BARREL "SHORT THROW" AUTO-LOAD .50 CALIBER BOTTOM MOUNTED MACHINE GUNS
19. PIVOTING DUAL-FEED AUTO-LOAD PILOT ACTIVATED .50 CALIBER MACHINE GUNS

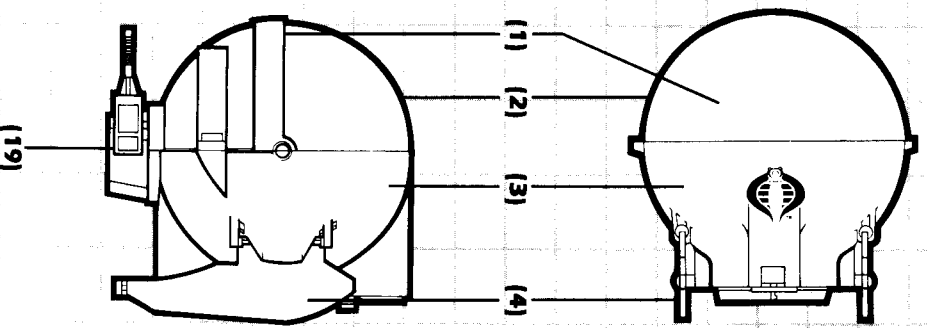

(19)