



Goosebumps™ TERROR in the Graveyard™ Game

INSTRUCTIONS

2 to 4 Players

CONTENT'S

Gameboard, 3 Sliding Platforms, 8 Pawn Cards, 36 Cards, 8 Plastic Pawns, 3 Plastic Tombs, Plastic Ghost Launcher, Plastic Skull, Parts Sheet, Label Sheet, 2 Dice.

ASSEMBLY

Here's a game fully set up for 4 players! Use Figure 1 as you assemble and set up the game.

FIGURE 1

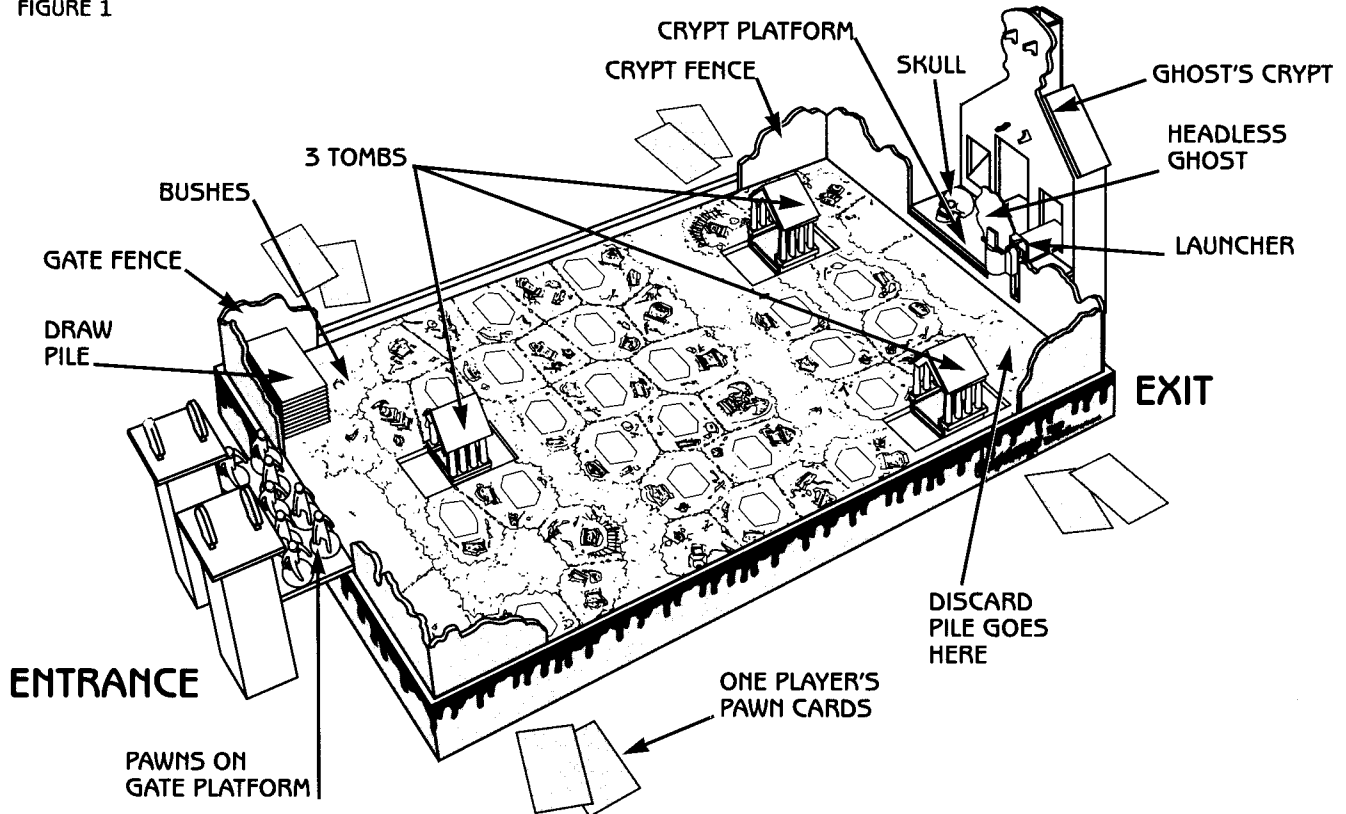

SLIDING PLATFORMS

Punch out all sliding platforms from the parts sheet. Punch in all holes and fold each platform firmly along its scored lines. (First fold the short ends under to support the long sides. Then fold the long sides down, forming a box shape.) Insert platforms into box bottom in the order shown in Figure 2.

GAMEBOARD AND TOMBS

1. Punch out all gameboard holes. Place gameboard over the sliding platforms as shown in Figure 3.

2. Separate each tomb half from the plastic runner: (1) Push down on its bottom so it breaks off cleanly from the connector. **Do not twist!** (2) Carefully move the tomb half up and down until it separates cleanly from the roof connector. **Do not twist!**

3. Press-fit the matching halves together to create three tombs (Mummy, Monster and Wolf). See Figure 3A. Insert the tombs into the openings in the gameboard. (They can be placed in any order.) See Figure 1 for placement.

FENCES

1. Punch out the Gate Fence and Crypt Fence from the parts sheet. Fold them along their scored lines. Insert them between the gameboard and the box bottom as shown in Figure 4.

FIGURE 2

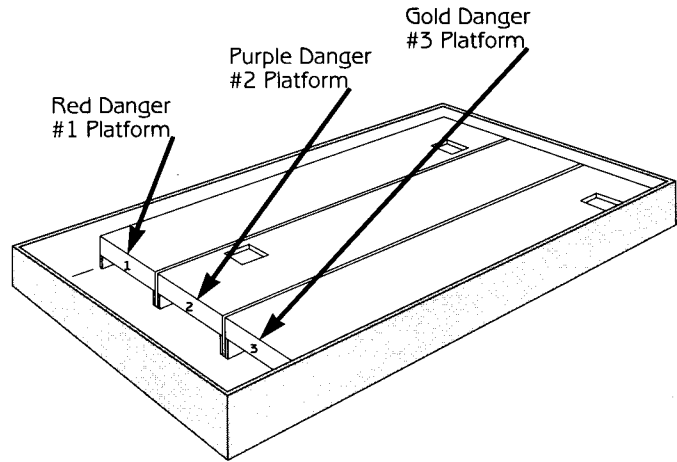

FIGURE 3

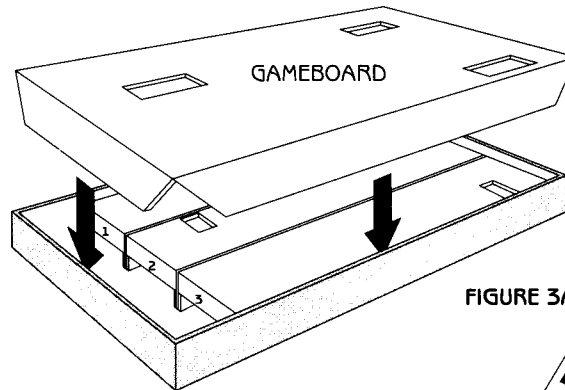

FIGURE 3A

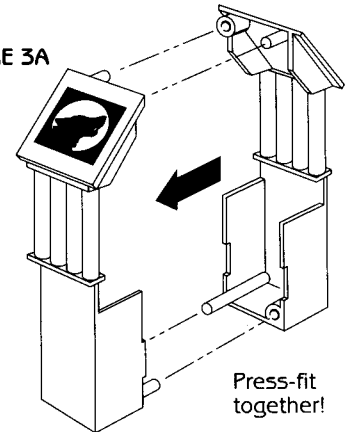
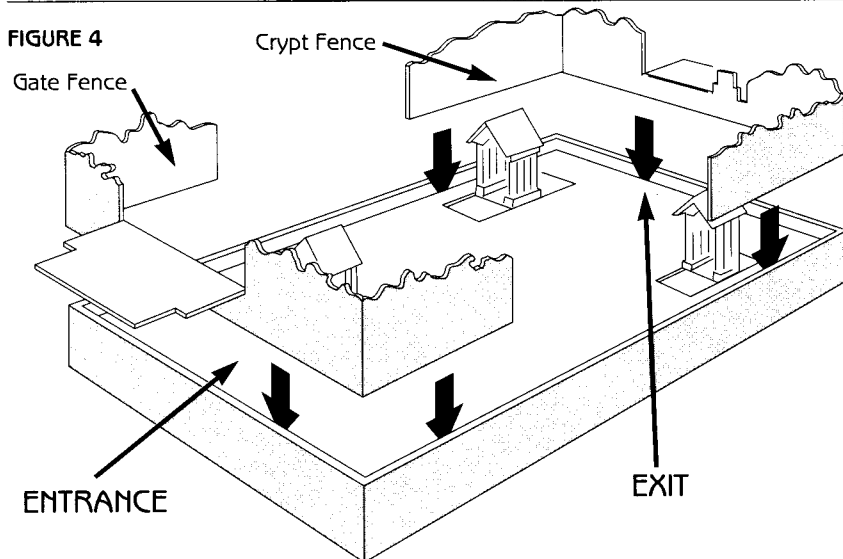

FIGURE 4



GHOST'S CRYPT

1. Punch out the Ghost's Crypt (and all of its holes), the Chute and the Chute Divider from the parts sheet. Fold each piece along its scored lines.

2. Insert the Chute Divider's tabs into the Crypt's slots. Then insert the Chute's tabs into the Crypt's top slots. See Figure 5. Then fold over the Crypt's roof and insert its tabs into the Chute Divider's slots. See Figure 5A.

3. Fold down the Crypt window's ramp and insert it into the back slot of the Crypt as you fold the Crypt together. See Figure 5B.

4. Then slide the Crypt's wall slots into the Crypt Fence's platform slots. See Figure 5C.

ENTRANCE GATE

1. Punch out the Entrance Gate and its Pillar Roofs from the parts sheet. Fold the Entrance Gate along its scored lines and attach its Pillar Roofs. See Figure 6.

2. Slide the Entrance Gate's pillar slots into the Gate Fence's platform slots. See Figure 6A.

FIGURE 5
Back View
of Crypt

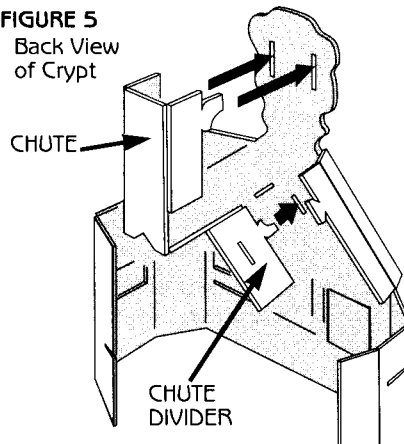

FIGURE 5A

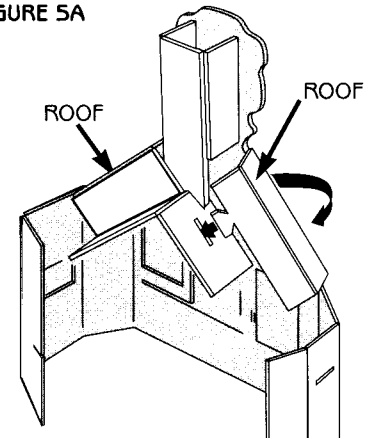

FIGURE 5B

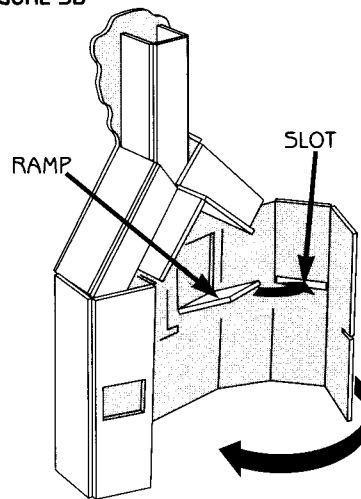

FIGURE 5C

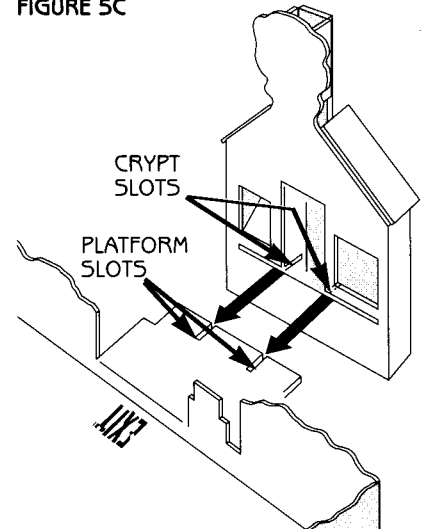

FIGURE 6
Back View of
Entrance Gate

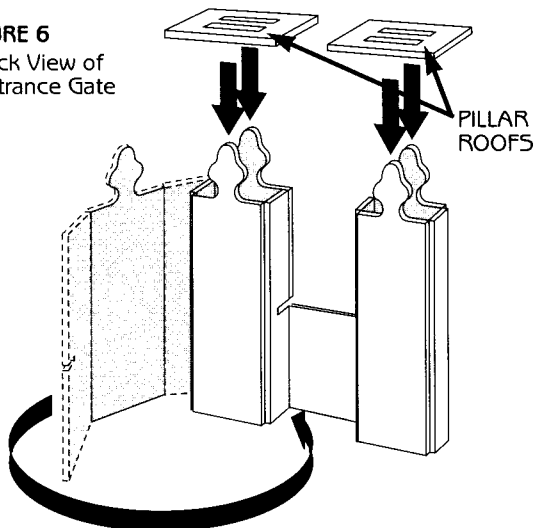
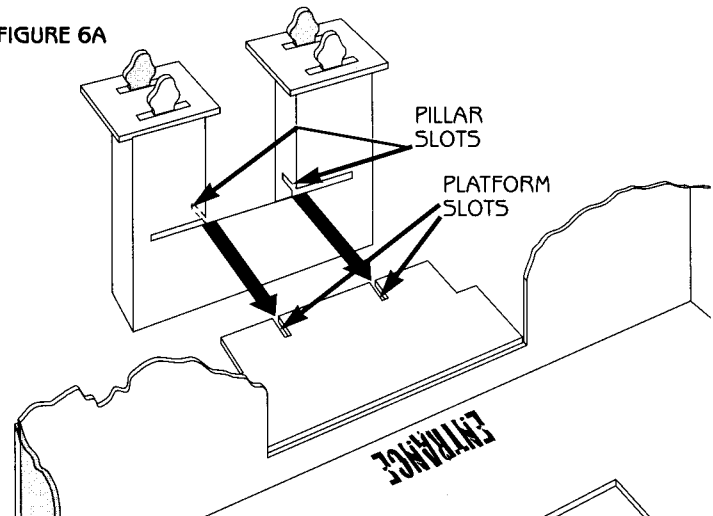

FIGURE 6A



HEADLESS GHOST AND LAUNCHER

1. Punch out the Headless Ghost from the parts sheet. (Be sure to punch out its hole.) Discard waste cardboard. Remove its Stand from the plastic runner. Firmly slide the Headless Ghost onto the Stand. See Figure 7.

2. Remove the Launcher's Beam, Holder and Cap from the plastic runner. Discard waste plastic. Snap-fit the Beam's pins one-at-a-time into the Holder's holes. Insert a spring into the spring chamber and secure it with the Cap. See Figure 7A.

3. Place the Launcher on the cardboard Crypt Fence Post so the Launcher's Beam rests inside the Crypt's right window. See Figure 7B.

4. Slide the Headless Ghost onto the Launcher as shown in Figures 7C and 7D.

To Test Launcher: Drop the plastic skull down the Crypt's Chute. It will roll out of either Crypt window. Try until it rolls out and knocks the Launcher, sending the Headless Ghost with its Stand flying. Then reset launcher.

DICE

Attach all number labels to the red die in any order. Attach the Monster, Mummy and Wolf symbol labels to the black die in any order.

PAWN CARDS

Remove the pawn cards from the cardboard parts sheet. Discard waste cardboard.



FIGURE 7

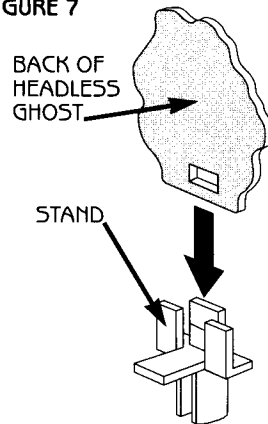

FIGURE 7A

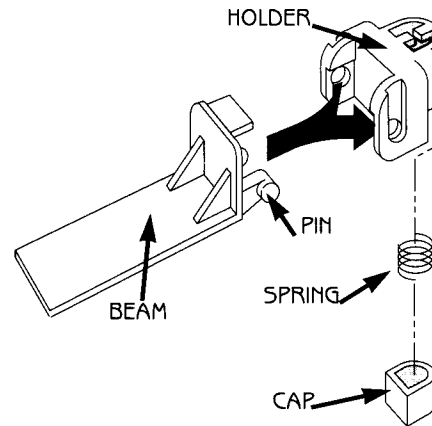

FIGURE 7B

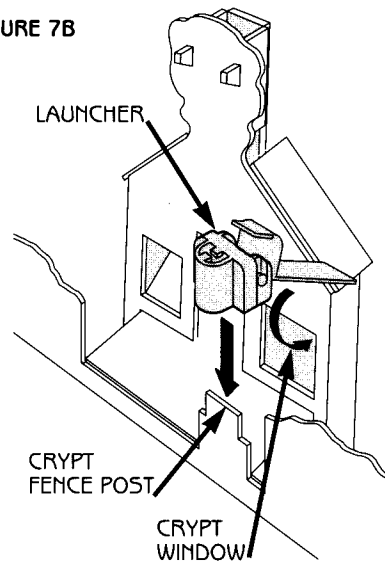

FIGURE 7C

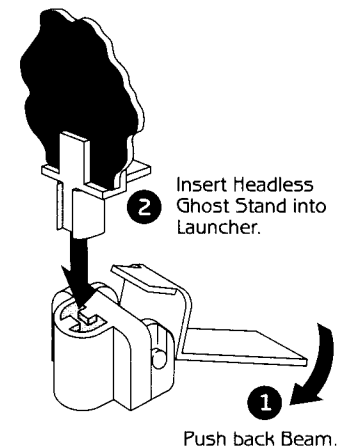
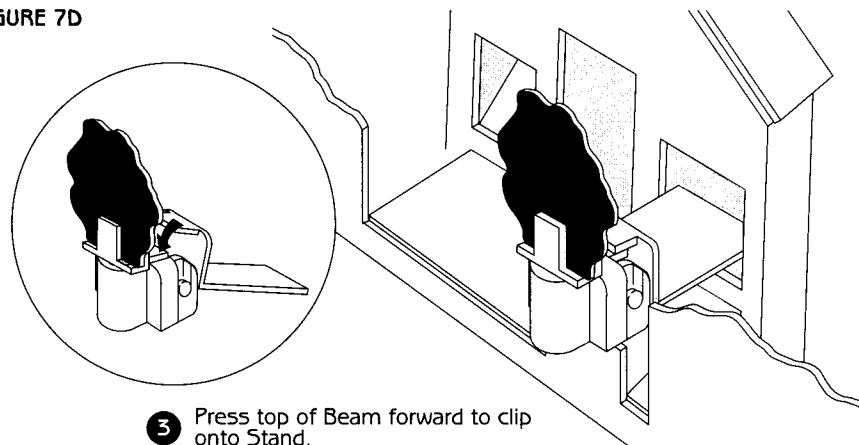

FIGURE 7D



THE STORY

Welcome to the living graveyard! You and your Goosebumps friends are trapped inside it and must now try to get out! You'll need to find a Magic Ring card to destroy the Headless Ghost who rules here. Collect cards as you walk amongst the tombstones, but watch out! The gameboard will move beneath you and skeleton hands will grab you! You may even fall into a tomb pit! You (or your friends) may be turned into monsters, too! So come play the game -- if you dare! Beware! Each new game tells a new tale of horror!



SETUP

Refer to Figure 1 for placement of the following:

1. Place the plastic skull on the Crypt platform.
2. Shuffle the card deck and place the cards facedown on the bushes near the Entrance to form a draw pile.
3. **Pick a Color and the Characters:** Choose two pawns of the same color and their matching color Pawn cards. Each player does the same. See Figure 8.

Your girl and boy pawns match the characters on your cards. (They're from the *Goosebumps*® books!) During the game, your pawns will collect cards. Be sure to place the cards with the particular pawn that collected them.

Put both pawns on the Gate platform and place your two Pawn cards in front of you. All players do the same.

4. Slide each tomb to its middle position. See Figure 9.

FIGURE 8



FIGURE 9

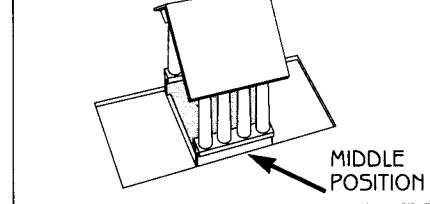

OBJECT

Collect a Magic Ring card and destroy the Headless Ghost.

HOW TO PLAY

The youngest player goes first. Play continues clockwise. Do the following steps on your turn. Each is explained below.

On Your Turn:

1. Roll both dice.
2. Move a tomb by the black symbol die. (Check the gameboard for space changes!)
3. Move one of your two pawns by the red number die (optional).

1. ROLL DICE

Roll the symbol die and the number die.

2. MOVE A TOMB

Move the tomb (that matches the symbol rolled) **one** position. For example, if you rolled a Wolf, move the Wolf tomb. See Figure 10.

FIGURE 10

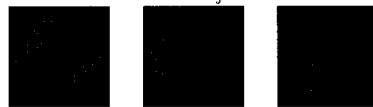

WOLF
TOMB

MUMMY
TOMB

MONSTER
TOMB

A tomb has 3 positions – a middle and two ends. To move, slide the plastic tomb one position forward or back. See Figure 10A. **Note:** This will shift the gameboard -- see *The Shifting Gameboard*.

A Tomb Pit

The position directly below the plastic tomb is a pit. The other two tomb positions are gameboard spaces that can be moved onto during play.

No pawn can be moved into a pit by die move or card direction. You can only fall into a pit if a tomb is moved.

If any pawn falls into a pit, that pawn is immediately out of the game. (Remove the pawn from the pit and place it on its matching Pawn card. Put all cards collected by that fallen pawn in the discard pile.)

FIGURE 10A. Tomb Positions

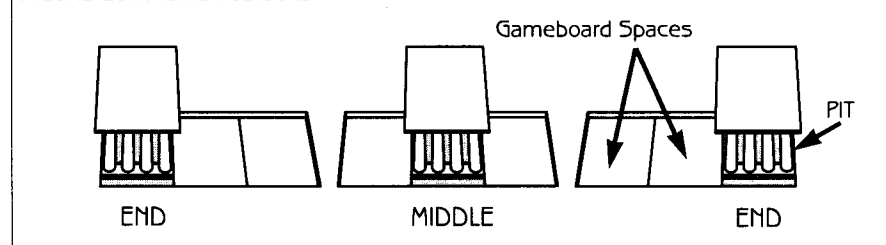

The Shifting Gameboard

Moving a tomb will change some gameboard spaces and affect your pawns and your opponents' pawns on your turn. After the gameboard shifts, all players should react immediately to these spaces if their pawns are now sitting on them:

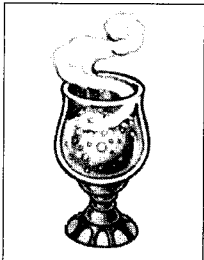

MAGIC POTION SPACE

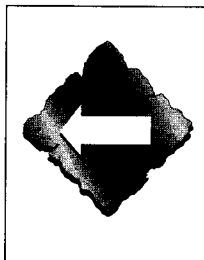

ARROW SPACE

Learn more about these spaces in detail under *Gameboard Spaces*.

3. MOVE YOUR PAWN

On your turn, move *one* of your pawns the full count of the number die roll. Then follow the directions for the space your pawn landed on. (See *Gameboard Spaces*.) If you do not wish to move or you cannot move, your turn is over.



BASIC PAWN MOVEMENT

- Always move the full count of the number die roll.
- A pawn may move in any direction to any adjacent space -- but cannot move diagonally through a corner of a space. See Figures 11 and 11A.
- A pawn cannot doubleback onto any of the same spaces on the same turn.
- A pit is not a game space. A player cannot move a pawn directly into an open tomb pit.
- A pawn cannot move across bushes or open pits. *Bushes and pits block all pawns*. See Figure 11B.
- A pawn cannot move if it is on a Skeleton Hand space.
- Always follow the directions for the space your pawn ends its move on.
- Pawns may share spaces and platforms.

FIGURE 11. Legal Move of 4

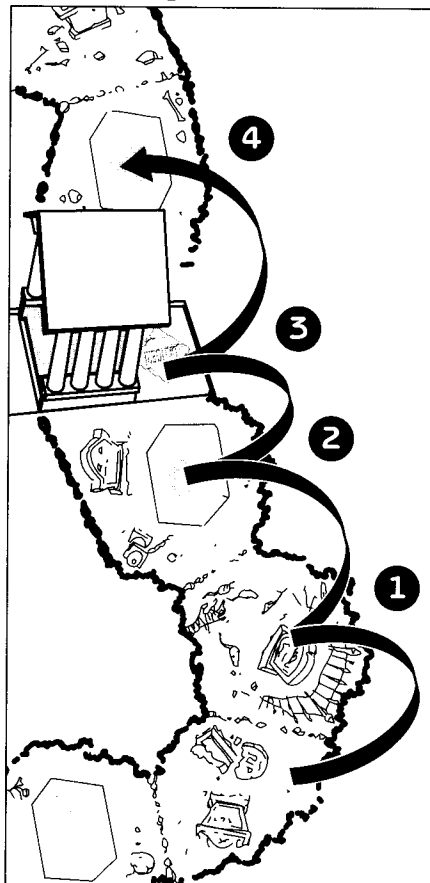

FIGURE 11A. Illegal Moves

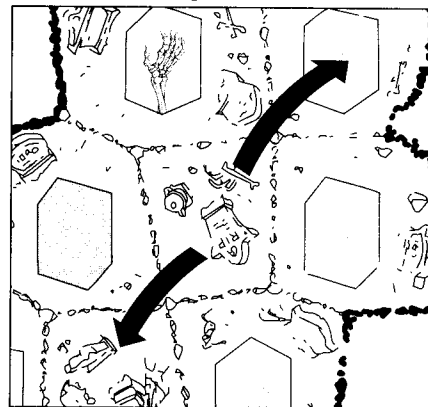
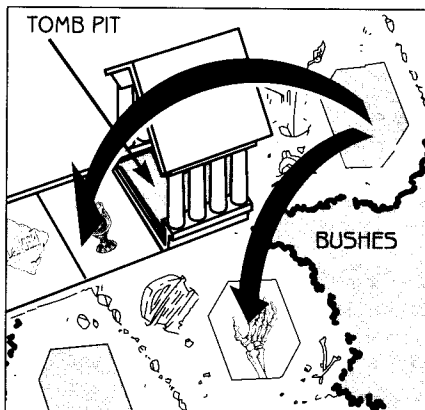

FIGURE 11B. Illegal Moves



GAMEBOARD SPACES

There are 6 different spaces. Do the following if your pawn lands there by die roll count; or is moved there by your card or an opponent's card; or if such a space appears under your pawn after a tomb is moved.

ANY GRASS SPACE: Do nothing.

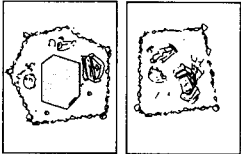

ARROW SPACE: Move your pawn immediately to the matching color Danger space!



DANGER SPACE: Stay here, but BEWARE! While your pawn is on this space, it may fall into the nearby tomb pit on someone else's turn and your pawn will be out of the game!



SKELETON HAND SPACE: Your pawn is paralyzed! It cannot leave this space until someone moves a tomb and changes the space. Try to move your other pawn. If both of your pawns are on



Skeleton Hand spaces, you *cannot* move on your turn.

MAGIC POTION SPACE: If your pawn is under a Monster card's spell, your pawn is cured by the magic potion! Remove the Monster card from the matching Pawn card and place the Monster card on the discard pile. (See more about *Monster Cards* below.)



If your pawn is *not* under a Monster card's spell, nothing happens.

"G" (GOOSEBUMPS CARD) SPACE: If your pawn is *not* under a Monster card's spell, pick a card from the draw pile and follow that card's directions. (See *Goosebumps Cards* below.)



IMPORTANT: You can draw a card only on your turn if you move here by die roll count or by card direction. If a tomb moves and the space under you changes to a "G" space, you do *not* draw a card.

GOOSEBUMPS CARDS

Some cards tell you to play them immediately; others to save them and play later. The 4 types of cards are explained below.

Hint: Play cards on your opponents during the game -- especially if they're getting near the Crypt!

You can play as many cards as you wish on your turn -- and at anytime during your turn, unless otherwise noted. Just read the stories on the cards and do as they say. If you run out of cards in the draw pile, shuffle the discard pile and start a new draw pile.

Remember: Your goal is to collect a Magic Ring card and race towards the Crypt!

1. PLAY NOW! CARDS

Read this card aloud immediately and follow its directions. Then place it facedown on the discard pile (unless it is a Monster card).

Monster Cards: If a card tells you to change an opponent or yourself into a Monster, place the Monster card faceup on any opponent's Pawn card; or faceup on the Pawn card of the pawn you just moved.



What to Do When You're a Monster: Once you have been turned into a Monster, you must find a magic potion to cure your pawn! On following turns, try to land on a Magic Potion space! If you do, you're cured immediately! Remove the Monster card and place it facedown on the discard pile. **Note:** If a tomb moves and a Magic Potion space appears underneath you, you're automatically cured! There is also a special *Play Now!* card which will cure all pawns who have been turned into Monsters. Watch for it!

MONSTER RULES

- Monster pawns are moved like regular pawns.
- All spaces affect a Monster pawn except the "G" space. If your Monster pawn lands there, you cannot draw any cards.
- You may play any cards saved by your Monster pawn.
- You cannot play a Monster card on a pawn that is already a Monster -- but you can play any other card on it.
- A Monster pawn cannot destroy the Headless Ghost -- even if it has a Magic Ring card. It has to be cured first. (See *Magic Ring Cards* for details.)

2. PLAY LATER! CARDS

Keep this card secret, place it underneath the Pawn card of the pawn that collected it, and save it to play later.

Magic Ring Cards:

If you have one or more Magic Ring cards, keep them secret and save them under your Pawn card. Then head for the Headless Ghost as fast as you can if you're not a Monster! You need this card to destroy the Headless Ghost. See *How to Win* below.



IMPORTANT: You cannot play a Magic Ring card that is saved under one of your pawns for your other pawn. So if your Sari girl pawn has a Magic Ring card saved underneath her Pawn card, your Gabe boy pawn cannot play it!



Monster Reversal Card: Save this card under your Pawn card. When a player plays a Monster card on that pawn, remove the Monster Reversal card and read it aloud. Place the Monster Reversal card on the discard pile and put the Monster card

on your opponent's Pawn card. Your opponent's pawn then becomes the Monster!

3. PLAY NOW OR LATER! CARDS

Play this card immediately or keep it secret and save it underneath your Pawn card to play later. When you play it, read it aloud and follow its directions. Then place it facedown on the discard pile.

4. PLAY ANYTIME! CARD

This card is special! You can use it anytime at all -- *even on someone else's turn!* Play this card immediately or keep it secret and save it underneath your Pawn card to play later. Read it aloud when you use it, follow its directions and then place it facedown on the discard pile.

HOW TO WIN

Destroy the Headless Ghost!

When your pawn has one or more Magic Ring cards, try to move it as quickly as you can to the Crypt platform. You do not have to move the full count of your number die roll to jump from the gameboard's Exit space onto the Crypt platform. **Note:** More than one player may be on the platform at the same time.

Once on the platform, show everyone your Magic Ring card and read it aloud. Now try to defeat the Headless Ghost by dropping the skull down the Crypt's chute.

- If the skull drops onto the Headless Ghost's Launcher and the Headless Ghost flies off, you win! Everyone can escape from the graveyard -- even those pawns who dropped into the tomb pits! See Figure 12.
- If the skull rolls out of the other Crypt window, try again on your next turn -- unless you have a *Play Now or Later!* card which lets you take another full turn now! If you do, be sure to roll the dice and move a tomb and a pawn again. **Remember:** You do not discard your Magic Ring card -- you can use the same one again. See Figure 12A.

FIGURE 12

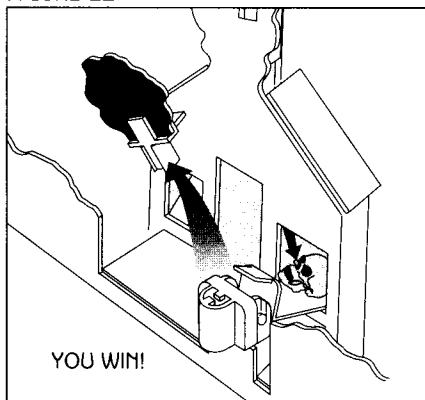

Milton Bradley Company
P. O. Box 1247
East Longmeadow, MA 01028

BEWARE!

While you wait for your next turn, an opponent could steal your Magic Ring card, move your pawn, switch places with your pawn, or turn your pawn into a Monster -- depending upon which cards are played! If your pawn is turned into a Monster, you must go find a Magic Potion before trying to destroy the Headless Ghost. If you lose your Magic Ring card, you must go find another one (unless you're lucky enough to have more than one saved for that pawn!)

Grave News

Anytime in the game, if you lose both of your pawns in the pits, you are immediately out of the game.

News from the Crypt

If all other players are out of the game, and you are the only surviving player left, you automatically win even if you do not destroy the Headless Ghost.



FIGURE 12A

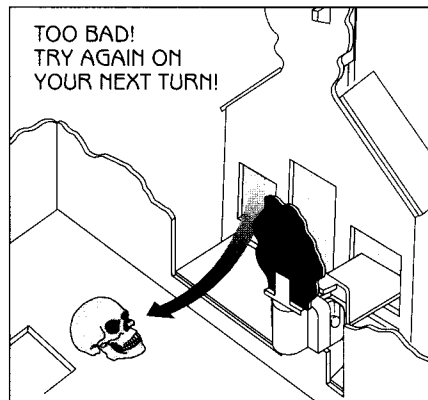

©1995 Parachute Press, Inc. All rights reserved.
Goosebumps is a trademark of Parachute Press, Inc.
All rights reserved.
©1995 Milton Bradley Company. All Rights Reserved. 4602-1