

## TO REPLACE BATTERIES

Use a Phillips/cross head screwdriver (not included) to loosen screw in battery compartment door (screw remains attached to door). Remove door. Remove and discard old batteries. Insert 3 x 1.5V "AA" or R6 size batteries. Alkaline batteries recommended. Replace door and tighten screw.

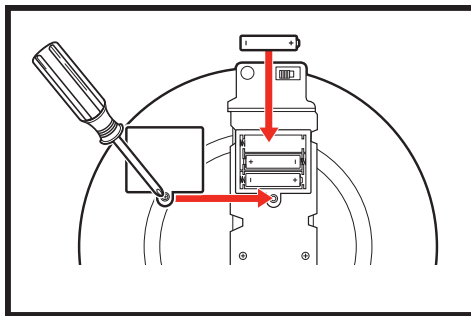

### ! CAUTION: TO AVOID BATTERY LEAKAGE

1. Be sure to insert the batteries correctly and always follow the toy and battery manufacturers' instructions;
2. Do not mix old and new batteries or alkaline, standard (carbon-zinc) or rechargeable (nickel-cadmium) batteries;
3. Always remove weak or dead batteries from the product.

### IMPORTANT: BATTERY INFORMATION

Please retain this information for future reference. Batteries should be replaced by an adult.

### ! CAUTION:

1. Always follow the instructions carefully. Use only batteries specified and be sure to insert them correctly by matching the + and - polarity markings.
2. Do not mix old batteries and new batteries, or standard (carbon-zinc) with alkaline batteries.
3. Remove exhausted or dead batteries from the product.
4. Remove batteries if product is not to be played with for a long time.
5. Do not short-circuit the supply terminals.
6. Should this product cause, or be affected by, local electrical interference, move it away from other electrical equipment. Reset (switching off and back on again or removing and re-inserting batteries) if necessary.
7. RECHARGEABLE BATTERIES: Do not mix these with any other types of battery. Always remove from the product before recharging. Recharge batteries under adult supervision. DO NOT RECHARGE OTHER TYPES OF BATTERIES.

#### FCC STATEMENT

This equipment has been tested and found to comply with the limits for a Class B digital device, pursuant to Part 15 of the FCC Rules. These limits are designed to provide reasonable protection against harmful interference in a residential installation. This equipment generates, uses and can radiate radio frequency energy, and, if not installed and used in accordance with the instructions, may cause harmful interference to radio communications. However, there is no guarantee that interference will not occur in a particular installation. If this equipment does cause harmful interference to radio or television reception, which can be determined by turning the equipment off and on, the user is encouraged to try to correct the interference by one or more of the following measures:

- Reorient or relocate the receiving antenna.
- Increase the separation between the equipment and the receiver.
- Consult the dealer or an experienced radio/TV technician for help.



© 2005 Hasbro. All Rights Reserved.  
TM & ® denote U.S. Trademarks.  
U.S. Patent No. 497956  
07809 P/N 6468340001

**PLAYSKOOL.COM**  
FOR NEW PRODUCTS AND OFFERS

Questions? Call: 1-800-PLAYSKL

AGES: 3+  
07809

**PLAYSKOOL**

# Bulls-Eye Bounce & Roll

Thank you for purchasing this  
**PLAYSKOOL** brand product!

Recommended for indoor use, away  
from direct sunlight, which interferes  
with toy's light technology.

Includes: BULLS-EYE BOUNCE &  
ROLL base, 1 small ring, 1 large ring,  
1 chute, 1 chute bottom, 8 screws,  
5 balls and instructions.

Adult assembly required.  
Phillips screwdriver (not  
included) needed for assembly.

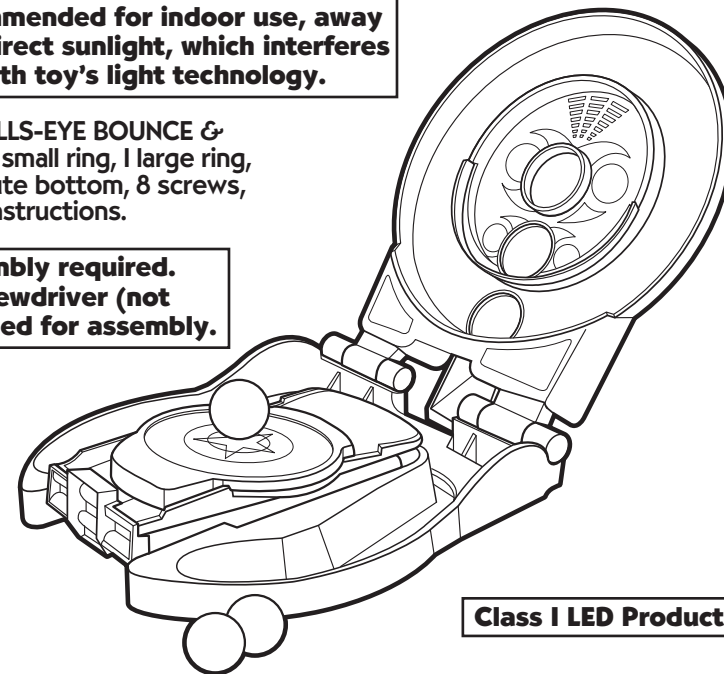

**Class I LED Product**

### ! CAUTION:

This product contains small parts which are necessary for assembly. Prior to and during assembly of this product, keep small parts out of children's reach. Small parts pose a choke hazard to children under 3 years.

Requires 3 x 1.5V "AA" or R6 size batteries.  
Alkaline batteries recommended. Phillips/  
cross head screwdriver (not included)  
needed to replace batteries.

**TO ASSEMBLE:** Here are the easy-to-follow instructions for assembling your **BULLS-EYE BOUNCE & ROLL** toy. Please follow assembly instructions in proper order for best results.

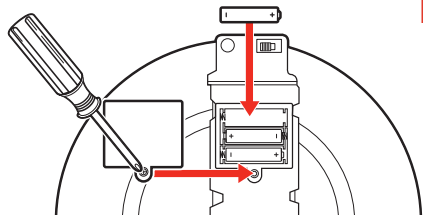

**1.** Remove the cover on the battery box located on the back of the chute. Using a Phillips/cross head screwdriver (not included), loosen the screw in the battery compartment door (screw remains attached to door). Remove door and insert 3 x 1.5V "AA" or R6 size batteries. Alkaline batteries recommended. Replace door, tighten screw and place the battery box back in the chute as shown.

**2.** Connect the chute bottom to the chute by sliding it onto the end of the chute as shown. The chute bottom will snap into place.

**3.** Connect the small ring to the back of the **BULLS-EYE BOUNCE & ROLL** base as shown. The ring should snap into place.

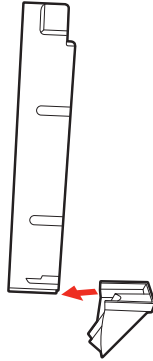
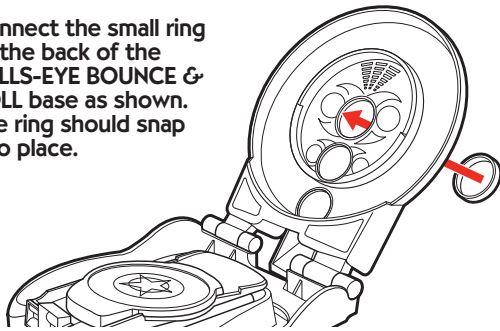

**4.** Connect the chute to the back of the **BULLS-EYE BOUNCE & ROLL** base by using the 8 screws (included). You will need a Phillips/cross head screwdriver to complete this step.

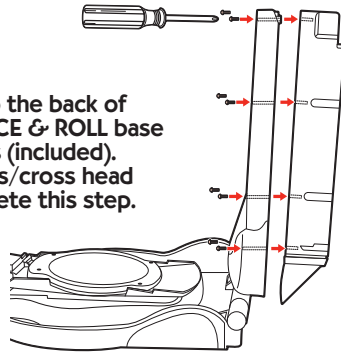

**5.** Connect the large ring to the front of the **BULLS-EYE BOUNCE & ROLL** base as shown. The ring should snap into place.

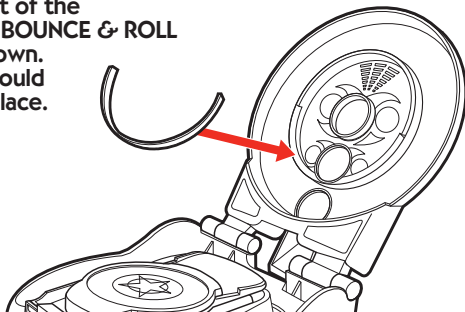

**NOW YOU'RE  
READY TO GET  
YOUR GAME ON!**

## PLAY FEATURES

A built-in announcer, electronic score keeping and cool arcade action keep the fun in high gear – in either bounce or roll mode! Here are some play suggestions to get you started:

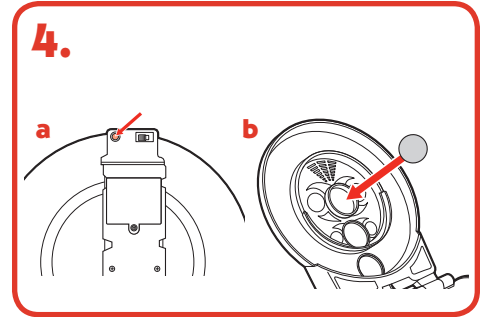
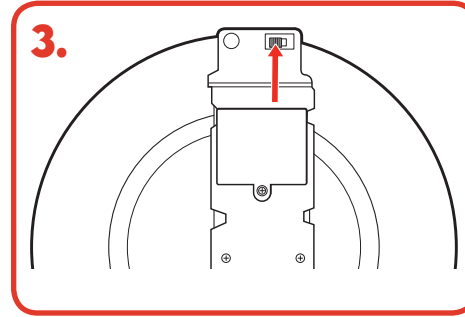
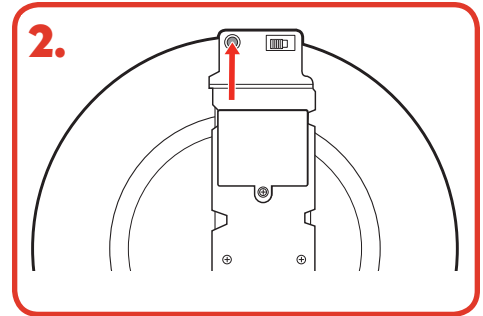
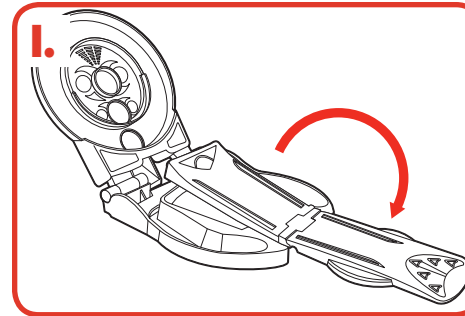

**1.** Bounce or roll - it's your choice!

The game base comes ready for "bounce" play. To use "roll" play, simply flip the bounce target backwards as shown to set up the rolling ramp.

**2.** On the back of the **BULLS-EYE BOUNCE** target where the chute is mounted, you will find a button that controls the game's sound level. To play a game with the announcer and score-keeper on, press the button once for "Sounds On" mode or twice for "Sounds Medium" mode. Pressing the button a third time will activate "Sounds Off" (quiet) mode.

**3.** Also on the back of the **BULLS-EYE BOUNCE & ROLL** base, you will find a three-position switch. Put the switch in position to select one of the following three games:

- **Game 1 - Target Practice:** This game allows you to roll or bounce the balls into the holes with no time limit or cumulative score keeping.
- **Game 2 - Match Me:** In this game, the announcer will tell you which target to hit. You can either roll or bounce to balls to hit the targets.
- **Game 3 - High Score Challenge:** It's a race to get the high score! You'll have 45 seconds to roll or bounce for the new record!

**4.** After you are finished playing, the toy will automatically shut off. You can resume play by pressing the "Sounds" button.